

FEDERAL FIRE SAN DIEGO

Hydraulics Manual



Union President _____

Chief Mary Anderson _____

Federal Fire san Diego



Federal Fire San Diego



Hydraulics Manual

Hydraulics Manual

Foreword

The role of the Fire Engineer is vital within the fire service. The Fire Engineer must supply adequate hose streams with the proper amount of water at effective, yet safe pressures in order to accomplish one of the fire service's basic missions – fire control. Expert control of the pump and of the hydraulics system of the fire engine is crucial.

Supplying the proper amount of water under the right amount of pressure is no easy task. The Fire Engineer must rely upon experience and quick effective guides to perform this vital function. In an emergency situation, there is no time to figure out long hydraulics formulas or perform exacting calculations.

The Federal Fire Department San Diego is proud to have among its personnel many highly qualified Fire Engineers. When these personnel move up within the organization, the Department hopes to maintain the high standards that these Fire Engineers have perpetuated. The Department is offering this text to help personnel develop their skills and expertise. As a result of this and similar efforts, the Department will be able to continue to provide quality fire protection to the residents of its jurisdictional area.

Directions for Use

This manual is set up to help you progress from simple to more complex computations. At each step you will be asked questions, and in most cases you will be given a choice of answers. When you choose the answer that you think is right, you will be directed to turn to another page where you will be given appropriate feedback.

In hydraulics problems there is an acceptable margin of error. If pressures are within 5 to 10 pounds per square inch (PSI) of the required PSI, little effectiveness is lost. Keep in mind that gauges are not 100% accurate.

Table of Contents

Title Page	i
Forward	ii
Purpose	iii
Reference	iii
Standards for Hydraulics Calculations	iv
Directions for Use	v
Table of Contents	vi
Chapter 1: Determining Engine Pressure	1
Nozzle Pressure	10
Friction Loss – Hose Diameter	21
Friction Loss – Length of Hoselay	25
Appliances	29
Elevation Differential – Head	33
Summary	37
Chapter II: Working the Basic Hydraulics Formula	38
Determining Nozzle Pressure	40
Computing Friction Loss	48
Reducing Friction Loss	54
IFSTA Friction Loss Formula	61
Determining Friction Loss for Appliances.	67
Principles of Head Pressure	73
Computing Head in Structures	85
Computing Head for Wildland Hoselays	90
Summary	96
Chapter III: Determining Nozzle Reaction	100
Chapter IV: Relay Pumping	114
Summary	132
Chapter V: Foam Operations	134
Summary	160
Chapter VI: Using the Field Hydraulics Reference Sheet	162
How to Use the Field Hydraulic Reference Sheet	164
How to Use the Wildland Hydraulics Reference Sheet	173
Solving Engine Pressure – Multiple Lines	177
Chapter VII: Solving Hydraulics Problems	183
Field Hydraulics Reference Sheets	226

Directions for Use

This manual is set up to help you progress from simple to more complex computations. At each step you will be asked questions, and in most cases you will be given a choice of answers. When you choose the answer that you think is right, you will be directed to turn to another page where you will be given appropriate feedback.

In hydraulics problems there is an acceptable margin of error. If pressures are within 5 to 10 pounds per square inch (PSI) of the required PSI, little effectiveness is lost. Keep in mind that gauges are not 100% accurate.

Chapter I

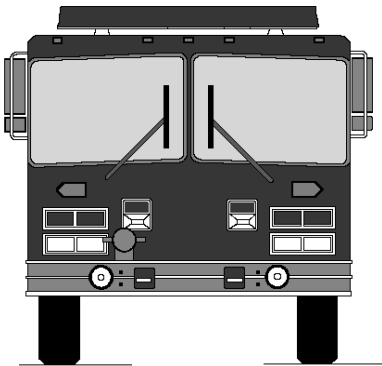

Determining Engine Pressure (EP)

$$EP = NP + FL + A (\pm) H$$

DETERMINING ENGINE PRESSURE (EP)

Engine pressure is the amount of pressure, in pounds per square inch (PSI), indicated on the pressure gauge or any given orifice discharge gauge. Stream pattern remaining the same, engine pressure is the major controlling factor that changes nozzle pressure and volume discharge. Adjusting the pump throttle changes engine pressure. The formula for determining engine pressure is:

$$EP = NP + FL + A (\pm) H$$

Given:

EP = Engine Pressure

NP = Nozzle Pressure

FL = Friction Loss per 100 feet of hose.

A = Appliance (if applicable)

(+) = increase in elevation above pump

(-) = decrease in elevation below pump

TURN TO PAGE 3

$$EP = NP + FL + A (\pm) H$$

What is Engine Pressure?

- 1) The amount of pressure in PSI at the discharge side of the pump.

TURN TO PAGE 4

- 2) The amount of pressure in PSI discharging at the nozzle.

TURN TO PAGE 5

$$EP = NP + FL + A (\pm) H$$

You said, "Engine pressure is the amount of pressure in PSI at the discharge side of the pump."

YOU ARE CORRECT!

MOVE ON TO PAGE 9

$$EP = NP + FL + A (\pm) H$$

You said, "Engine pressure is the amount of pressure in PSI discharging at the nozzle." You apparently don't understand engine pressure; so let's try again.

Visualize yourself running the pump on a fire engine. You are standing at the pump level. You are running the throttle out, which increases the RPM's of the pump, and notice the pressure gauge at the pump panel increase from 50 PSI to 100 PSI. This is energy created by the pump which makes the water move through the plumbing on the fire engine and hoses connected to the discharges on the fire engine. The engine pressure is telling you the amount of pressure being developed at the discharge side of the pump and up to the discharge outlets on the fire engine. The pressure registering on the engine pressure gauge will not be the same at the nozzle because energy (pressure) is being used up overcoming friction in the hose. Energy (pressure) is also used up by pumping water to levels higher than the pump. Water weighs 8.35 pounds per gallon and this weight is using up some of the engine pressure.

TURN TO PAGE 6

$$EP = NP + FL + A (\pm) H$$

So Engine Pressure is?

- 1) The amount of pressure (PSI) discharging at the nozzle.

TURN TO PAGE 7

- 2) The amount of pressure (PSI) registering on the engine pressure gauge, and is the amount of pressure (PSI) at the discharge side of the pump and all discharge outlets.

TURN TO PAGE 8

$$\mathbf{EP = NP + FL + A (\pm) H}$$

You said, "Engine pressure is the amount of pressure (PSI) discharging at the nozzle."

THAT IS INCORRECT

RETURN TO PAGE 2 AND TRY AGAIN

$$EP = NP + FL + A (\pm) H$$

You said, "Engine pressure is the amount of pressure (PSI) registering on the engine pressure gauge and is the amount of pressure (PSI) at the discharge side of the pump and all discharge outlets."

FANTASTIC!

NOW TURN TO PAGE 9

$$EP = NP + FL + A (\pm) H$$

Facts that you must know as a Pump Operator in order to determine engine pressure [$EP = NP + FL + A \pm H$] are:

- 1) Nozzle Pressure (NP)
- 2) Size of tips or nozzle (FL)
- 3) Diameter of hose (FL)
- 4) Length of hose in lay (FL)
- 5) Appliance (A)
- 6) Elevation differential either above or below from pump to nozzle ($\pm H$)

These six facts are needed in all cases to determine engine pressure. So make sure you understand these facts and write them on your scratch paper or record them in your memory bank.

TURN TO PAGE 10

$$EP = NP + FL + A (\pm) H$$

NOZZLE PRESSURE (NP)

Fire streams are divided into two general categories: solid streams and fog streams.

- 1) A solid stream is used when a large concentration of water is desired in one specific area or when a long reach is required. There are two basic ways of applying water on fires through solid stream nozzles: hand held tips on nozzles, and tips on master stream appliances. Through extensive testing it was found that on hand held tips the best operating nozzle pressure is 50 PSI. On master stream appliances the best operating nozzle pressure is 80 PSI.
- 2) Fog streams produce the most water surface for heat absorption, but also have the shortest range. Fog nozzles are designed to work most effectively at 100 PSI. Fog nozzles are used on hand held lines as well as on master stream appliance. While being used either way, the nozzle pressure would be the same, 100 PSI.

TURN TO PAGE 11

$$EP = NP + FL + A (\pm) H$$

When computing hydraulics problems, you must include the nozzle pressure. The following nozzle pressures won't change and must be added in on all problems:

TIPS – Solid Streams

Hand held lines 50 PSI NP

Master Stream appliances 80 PSI NP

COMBINATION NOZZLES – Fog Streams

Hand held and Master Stream appliances 100 PSI NP

TURN TO PAGE 12

$$EP = NP + FL + A (\pm) H$$

When computing engine pressure, you must include the nozzle pressure. Which are the four standard nozzle pressures? (Choose either #1 or #2 below.)

- | | | |
|----|---------------------------|------------|
| 1) | Hand held tips | 50 PSI NP |
| | Master stream tips | 80 PSI NP |
| | Hand held fog nozzles | 100 PSI NP |
| | Master stream fog nozzles | 100 PSI NP |

TURN TO PAGE 13

- | | | |
|----|---------------------------|------------|
| 2) | Hand held tips | 80 PSI NP |
| | Master stream tips | 50 PSI NP |
| | Hand held fog nozzles | 80 PSI NP |
| | Master stream fog nozzles | 150 PSI NP |

TURN TO PAGE 14

$$EP = \mathbf{NP} + FL + A (\pm) H$$

CORRECT!

Nozzle pressure is the easiest part of the hydraulics problem because all you have to remember is 50 NP, 80 NP, and 100 NP. So don't forget to add it in the problem.

TURN TO PAGE 15

$$EP = \mathbf{NP} + FL + A (\pm) H$$

WRONG

Perhaps the statement on nozzle pressure wasn't clear enough, so

GO BACK TO PAGE 11 and read the explanation again.

$$EP = NP + FL + A (\pm) H$$

When solving hydraulics problems, you must always consider Nozzle Pressure (NP), Friction Loss (FL), Appliance (A), and Head (\pm H) in order to come up with the correct Engine Pressure (**EP**).

A practical way of using this formula in the field is to organize your scratch paper so that you will not forget to solve a part of the hydraulics problem.

EXAMPLE:

(Scratch Paper)

NP= _____

FL = _____

(Blank area to figure problem)

A = _____

H = _____

EP = _____

What are the four segments of the hydraulics formula needed when determining Engine Pressure for any hoselay?

Fill in the blanks:

EP = _____ + _____ + _____ (\pm) _____

TURN TO PAGE 16

$$\mathbf{EP = NP + FL + A (\pm) H}$$

If you answered $EP = NP + FL + A (\pm) H$,

YOU ARE DOING GREAT!

TURN TO PAGE 17

$$EP = NP + FL + A (\pm) H$$

SIZE OF TIPS OR NOZZLES (FL)

The size of the tip or nozzle, plus pressure, determines the gallons per minute (GPM). As an example: a ½ inch tip at 50 PSI flows 52 GPM, and a 1 inch tip at 50 PSI flows 210 GPM. The (GPM) flow is the major factor that causes friction loss in fire hose. The larger the tip or nozzle, the more friction loss involved. To determine the friction loss, you must know the size of the tip or nozzle so that the correct GPM figure for that size nozzle is used.

TURN TO PAGE 18

$$EP = NP + FL + A (\pm) H$$

Why must you know the size of the tip or nozzle when you are solving hydraulics problems?

- 1) The size of the tip or nozzle determines the GPM flow for computing friction loss.

TURN TO PAGE 19

- 2) The size of the tip or nozzle determines the size of the hose to be used.

TURN TO PAGE 20

$$EP = NP + \mathbf{FL} + A (\pm) H$$

You answered, "The size of the tip or nozzle determines the GPM to be used."

RIGHT! You are doing fine!

TURN TO PAGE 21

$$EP = NP + \mathbf{FL} + A (\pm) H$$

UH, OH! Perhaps we weren't clear.

The size of the tip or nozzle determines the GPM to be used for that particular size nozzle in determining friction loss.

RETURN TO PAGE 17 AND READ AGAIN

$$EP = NP + \mathbf{FL} + A (\pm) H$$

HOSE DIAMETER (FL):

The size of the hose determines the amount of friction loss for each 100 foot section of hose. The smaller the diameter, the more friction loss involved. The larger the diameter, the less friction loss involved. You must know the diameter of the hose in order to determine the friction loss for the hose.

TURN TO PAGE 22

$$EP = NP + FL + A (\pm) H$$

Why is it necessary to know the diameter of the hose when computing friction loss?

- 1) To determine the amount of flow.

TURN TO PAGE 23

- 2) To be able to use the correct figure to determine friction loss for each 100 foot section of hose.

TURN TO PAGE 24

$$EP = NP + FL + A (\pm) H$$

YOUR ANSWER IS INCORRECT.

Flow is determined by nozzle size and nozzle pressure.

RETURN TO PAGE 21 AND READ THE PARAGRAPH AGAIN.

$$EP = NP + \mathbf{FL} + A (\pm) H$$

Your answer, "To use the correct figure to determine friction loss for each 100 feet of hose," is right.

YOU ARE DOING FINE!

GO TO PAGE 25

$$EP = NP + \mathbf{FL} + A (\pm) H$$

LENGTH OF HOSELAY (FL)

In order to determine the amount of friction loss in a hoselay, you must know the entire length of the hoselay. All friction loss factors are computed in 100 foot lengths of hose. So if you have a ½ inch tip and a 1 ½ inch hose, the friction loss is 6 PSI per hundred feet of 1 ½ inch hose. Remember, friction loss computation is based on 100 foot lengths.

TURN TO PAGE 26

$$EP = NP + FL + A (\pm) H$$

In order to determine the amount of friction loss in a hoselay, you must know the entire length of the lay, because friction loss is computed in _____.

- 1) 100 foot lengths of hose.

TURN TO PAGE 27

- 2) 50 foot lengths of hose.

TURN TO PAGE 28

$$EP = NP + \mathbf{FL} + A (\pm) H$$

You answered, "100 foot lengths."

CORRECT!

TURN TO PAGE 29 AND CONTINUE

$$EP = NP + \mathbf{FL} + A (\pm) H$$

You answered, "50 foot lengths."

WRONG.

RETURN TO PAGE 25

$$EP = NP + FL + A (\pm) H$$

APPLIANCES (A)

There is loss of pressure any time an appliance (A) is added to a hoselay. This loss of pressure is due to appliance friction loss. These losses vary widely as they are affected by the appliance size, fittings, bends, design, condition, and rate of flow. As a result, appliance friction loss has to be added to hoselays when computing engine pressure.

Forestry Tee	5 PSI
Wye, Siamese	10 PSI
Manifolds	10 PSI
Portable Monitors	15 PSI
Engine (Relay Pumping)	20 PSI
Standpipe (Head not included)	25 PSI
Ladder Pipe 100 foot E-One	90 PSI
50 foot Telesquirt	65 PSI

TURN TO PAGE 30

$$EP = NP + FL + A (\pm) H$$

Appliance friction loss is added when computing engine pressure whenever an appliance is used in a hoselay because _____.

- 1) There is a loss of pressure any time an appliance is added.

TURN TO PAGE 31

- 2) Appliances are heavy.

TURN TO PAGE 32

$$EP = NP + FL + A (\pm) H$$

YOU ANSWERED CORRECTLY!

Appliances in a hoselay cause additional friction loss due to the extra couplings and change in the direction of flow. Whenever an appliance is used, this additional friction loss must be added when computing engine pressure.

PLEASE CONTINUE TO PAGE 33

EP = NP + FL + A (±) H

Well, since you missed this one, it must be time for a short break.

After you are refreshed, **RETURN TO PAGE 29** and try it again.

YOU CAN DO IT!

$$EP = NP + FL + A (\pm) H$$

ELEVATION DIFFERENTIAL - HEAD ($\pm H$)

Note: The nozzle is either above (+) or below (-) the pump.

Water weighs 8.35 pounds per gallon. Therefore, on hoselays below the pump, the weight of the water traveling downhill is going to increase the pressure (PSI) in the hose due to gravity.

Likewise, on hose lays above the pump, the weight of the water is working against the pump. An increase in pump pressure is necessary to move the water above the pump. Elevation differential, either above or below the pump, must be known in order to compensate engine pressure to meet the needs of the hoselay.

TURN TO PAGE 34

$$EP = NP + FL + A (\pm) H$$

Elevation differential, either above or below the pump, must be known in order _____.

- 1) To increase or decrease engine pressure to meet the needs of the hoselay.

TURN TO PAGE 35

- 2) To allow the Pump Operator to select the proper nozzle or tip.

TURN TO PAGE 36

$$EP = NP + FL + A (\pm) H$$

You answered, "To increase or decrease engine pressure to meet the needs of the hoselay."

RIGHT!

TURN TO PAGE 37 AND CONTINUE

$$EP = NP + FL + A (\pm) H$$

OOPS, YOU MISSED THIS ONE.

RETURN TO PAGE 33 AND TRY IT AGAIN

$$EP = NP + FL + A (\pm) H$$

CHAPTER I SUMMARY

ENGINE PRESSURE

- 1) Engine pressure is the amount of pressure in PSI registering on the pressure gauge at the discharge side of the pump. Engine pressure is the major controlling factor, which changes nozzle pressure or volume discharge.
- 2) The formula for solving hydraulics problems is:

$$EP = NP + FL + A (\pm) H$$

- 3) Facts which you must know as a Pump Operator in order to determine engine pressure (EP) are:

- A. Nozzle Pressure (NP)
- B. Size of tip or nozzle (FL)
- C. Diameter of hose (FL)
- D. Length of hose in lay (FL)
- E. Appliance (A)
- F. Elevation differential, either above or below from pump to nozzle ($\pm H$)

TURN TO PAGE 38

Chapter II

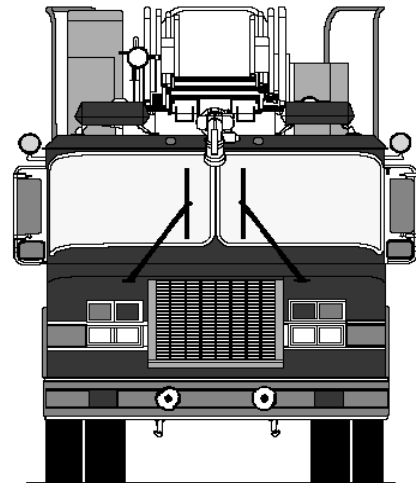
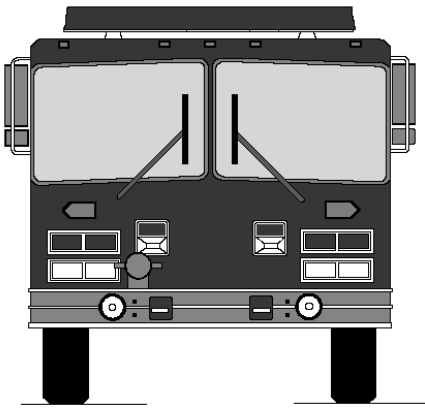

WORKING THE BASIC HYDRAULICS FORMULA

$$EP = NP + FL + A (\pm) H$$

$$EP = NP + FL + A (\pm) H$$

WORKING THE BASIC HYDRAULICS FORMULA

In this portion of the programmed text, you are going to work with the basic hydraulics formula: $EP = NP + FL + A (\pm) H$. Then, taking each factor, you will begin to solve problems. You will begin with **NP** (Nozzle Pressure).

$$EP = NP + FL + A (\pm) H$$

To determine Engine Pressure (EP) the first part of the formula to be solved is Nozzle Pressure (NP). Nozzle Pressure has to be added in the formula when nozzles are used. This pressure (PSI) is required because it is the pressure, which is needed to make the solid stream (tip) or fog stream (combination nozzle) operate effectively. If Nozzle Pressure (NP) were not added into the formula, you would not have an effective fire stream.

It is necessary to standardize some terms when referring to nozzles. This enables you to operate in the field with other firefighters, using the same language.

TURN TO PAGE 40

$$EP = NP + FL + A (\pm) H$$

Solid Streams

On any hoselay producing a solid stream, whether the stream is being produced by hand held lines or by a master stream appliance, the nozzle is called a **tip**.

The following Nozzle Pressure (NP) is to be used in computing Engine Pressure (EP) for solid streams.

NP 50 PSI ... Hand Held Tip

NP 80 PSI ... Master Stream Appliance Tip

Fog Streams

On any hoselay producing fog streams, whether the streams are being produced by hand held lines or by a master stream appliance, the nozzle is called a **combination nozzle**.

The following Nozzle Pressure (NP) is to be used in computing Engine Pressure (EP) for fog streams:

NP 100 PSI ... Hand Held Combination Nozzle

NP 100 PSI ... Master Stream Combination Nozzle

TURN TO PAGE 41

$$EP = NP + FL + A (\pm) H$$

The following examples illustrate the symbols used (T for tip or C for combination) in all of the subsequent problems to indicate the type of nozzle on the hoselay.

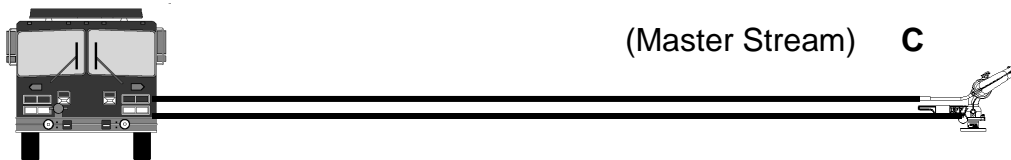
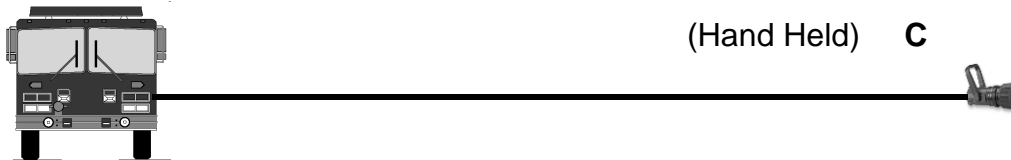
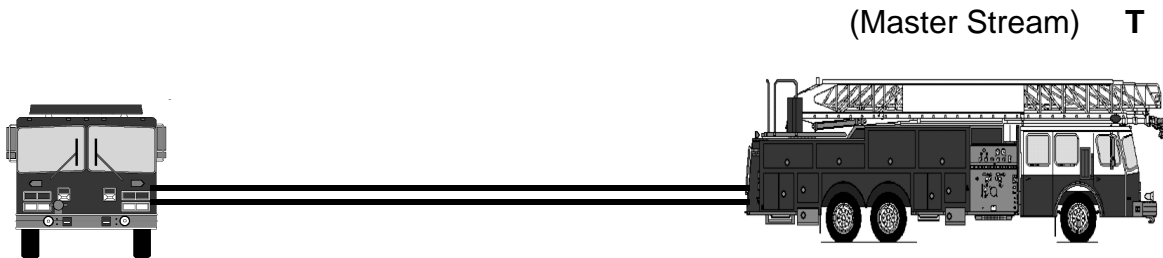
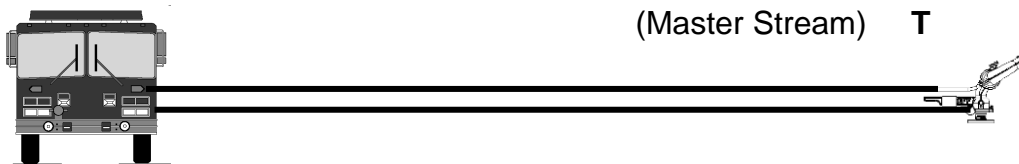
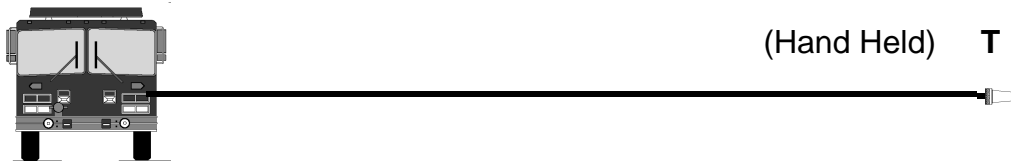

TURN TO PAGE 42

$$EP = NP + FL + A (\pm) H$$

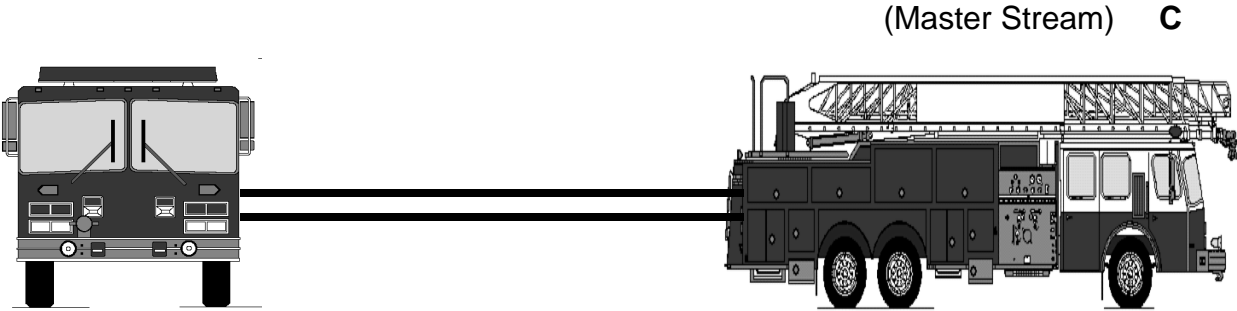

TURN TO PAGE 43

$$EP = \mathbf{NP} + FL + A (\pm) H$$

1) Solve

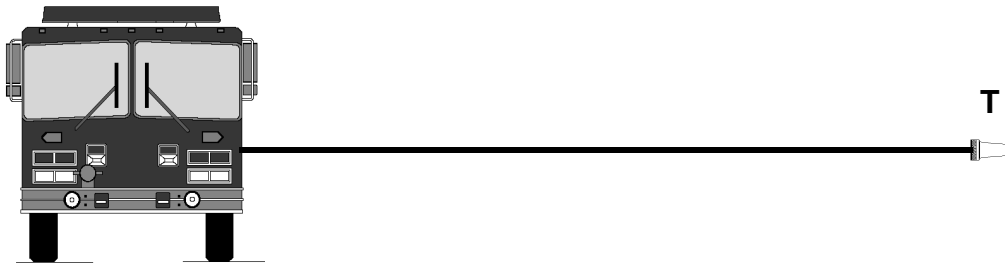

Write in NP

NP = _____

TURN TO PAGE 44 FOR THE CORRECT ANSWER

$$EP = NP + FL + A (\pm) H$$

2) ANSWER: $NP = 50 \text{ PSI}$

Remember that on all hand held tips the most effective Nozzle Pressure is 50 PSI. Effective in this case means it is easier and safer for firefighters to maneuver and operate the hand line.

3) Solve

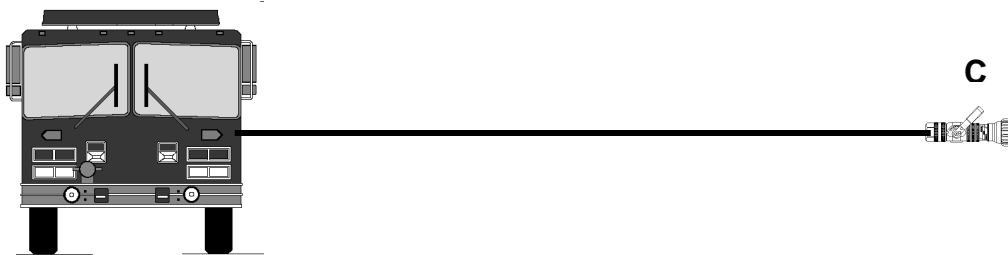

Write in the NP

NP = _____

TURN TO PAGE 45 FOR THE CORRECT ANSWER

$$EP = NP + FL + A (\pm) H$$

2) ANSWER: NP = 100 PSI

All combination nozzles, whether hand held or on master stream appliances, are designed to operate at 100 PSI, and their GPM flows are calculated for 100 PSI Nozzle Pressure.

However, you and your firefighter may find that less nozzle pressure may be easier and safer to operate on the fireground. Work with your Company Officer in determining what pressures will be most effective in specific situations, (e.g. interior vs. exterior firefighting, various hose sizes, and types of combination nozzles, etc.).

Just keep in mind that for test purposes, 100 PSI NP will be used for all combination nozzle problems, whether hand held or master stream.

3) Solve

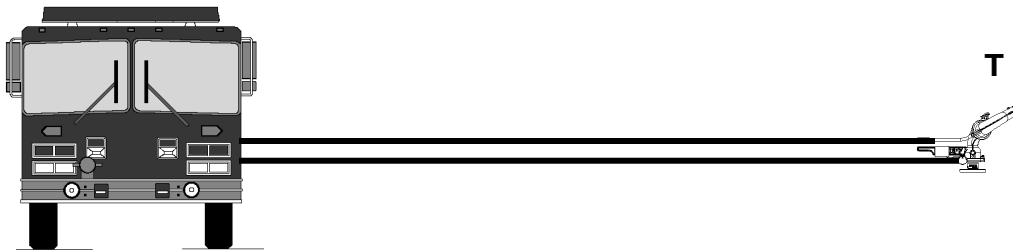

Write in the NP

NP = _____

TURN TO PAGE 46 FOR THE CORRECT ANSWER

$$EP = NP + FL + A (\pm) H$$

3) ANSWER: $NP = 80 \text{ PSI}$

On master stream appliances with straight bore tips; our standard nozzle pressure is 80 PSI.

4) Solve

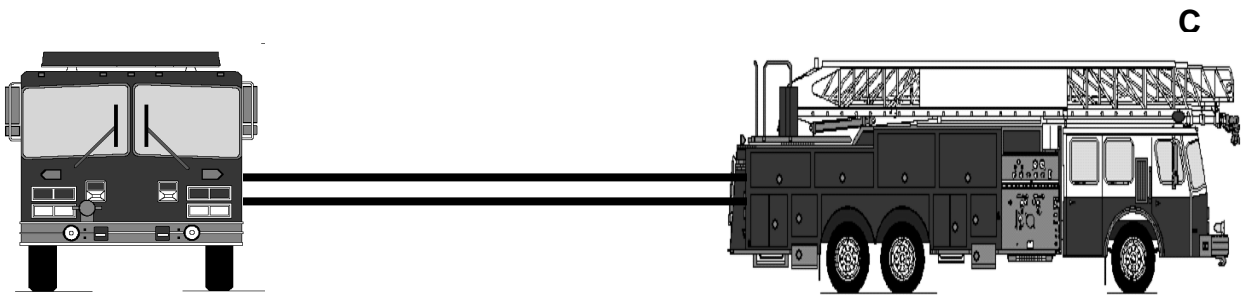

Write in the NP

NP = _____

TURN TO PAGE 47 FOR THE CORRECT ANSWER

$$EP = NP + FL + A (\pm) H$$

4) *ANSWER: NP = 100 PSI*

Remember that with combination nozzles it makes no difference whether it is hand held or on a master stream appliance, the Nozzle Pressure (NP) is always 100 PSI.

If anything is unclear with regards to Nozzle Pressure, return to page 39 and cover the material again. If you understand Nozzle Pressure, turn to page 48 and begin working with the next factor of the Hydraulics Formulas: COMPUTING FRICTION LOSS (FL)

TURN TO PAGE 48

$$EP = NP + FL + A (\pm) H$$

COMPUTING FRICTION LOSS (FL)

When two items rub together there is a loss of energy. This loss is caused by friction. This also applies to water flowing through couplings, changing direction around curves and kinks, and rubbing on the interior rubber surface of a firehose.

In order to produce effective fire streams, the amount of Friction Loss (FL) in the firehose, between the engine and the nozzle, must be known. This Friction Loss is determined by the amount of water flowing in gallons per minute (GPM). The greater the GPM in a given size and length of hose, the greater the Friction Loss. Since the amount of hose used between the engine and the nozzle will not always be the same, it is easiest to consider Friction Loss in terms of a common unit length of hose.

Friction Loss (FL) is therefore expressed in pounds per square inch (PSI) per 100 feet of hose.

TURN TO PAGE 49

$$EP = NP + FL + A (\pm) H$$

In order to produce effective fire streams you must know the amount of Friction Loss in the firehose, between the engine and the nozzle. **Friction Loss calculations are computed in ___ feet of hose.** Therefore, each length added, whether Head ($\pm H$), increases Friction Loss.

- 1) 50 foot lengths

TURN TO PAGE 50

- 2) 100 foot lengths

TURN TO PAGE 50

$$EP = NP + FL + A (\pm) H$$

If you answered 50 foot lengths, you should pay closer attention to what you are reading.

If you answered 100 foot lengths, YOU ARE CORRECT! You seem to have not only grasped how to follow directions in the text, but you have also comprehended the information contained herein.

All friction loss factors are computed in 100 foot lengths of hose to make it easier to compute Friction Loss in the field. Here is an example:

First, let's say you have a 1 inch smooth bore tip on the end of a 2 ½ inch hand held hose. If you look at the Field Hydraulics Reference Sheet (FHRS), which is in the back of this manual, and you'll see that a 1 inch tip on a 2 ½ inch hose has a Friction Loss factor of 9 PSI. This 9 PSI Friction Loss is for each 100 foot of 2 ½ inch hose, with a hand held, smooth bore tip.



Based on the information above, a 1000 foot 2 ½ inch hoselay with a 1 inch tip has how much Friction Loss?

- 1) 90 PSI FL

TURN TO PAGE 51

- 2) 160 PSI FL

TURN TO PAGE 52

EP = NP + **FL** + A (\pm) H

You answered 90 PSI FL.

Congratulations!

TURN TO PAGE 53 AND CONTINUE

$$EP = NP + \mathbf{FL} + A (\pm) H$$

GO BACK TO PAGE 50 AND CHECK YOUR MATH

$$EP = NP + FL + A (\pm) H$$

FACTS ABOUT FRICTION LOSS

- 1) The smaller the diameter of hose, the more Friction Loss involved.
- 2) Friction Loss is computed in 100 foot lengths of hose. So each length of hose added, Head ($\pm H$), increases Friction Loss.
- 3) The larger the diameter of hose, the less Friction Loss involved.
- 4) 1 ½ inch hose has approximately 2 times the Friction Loss of 1 ¾ inch hose.
- 5) 1 ¾ inch hose has approximately 6 times the Friction Loss of 2 ½ inch hose.
- 6) 2 ½ inch hose has approximately 8 times the Friction Loss of 4 inch hose.

TURN TO PAGE 54

$$EP = NP + FL + A (\pm) H$$

REDUCING FRICTION LOSS

There are four methods of overcoming excessive Friction Loss (FL) in hose lines while working on a fire:

- 1) Reduce the nozzle pressure. If the nozzle pressure is reduced, the discharge will be less; therefore, the Friction Loss will decrease.

CAUTION: This may prevent the fire stream from performing the required task.

- 2) Reduce the size of the nozzle tip and maintain the same nozzle pressure. Reducing the tip size and maintaining the same nozzle pressure reduces the discharge GPM.

CAUTION: The quantity of water being discharged may not be sufficient to cool the fire in order to accomplish extinguishment.

- 3) Lay a parallel hose line, or increase the hose size. With all other factors remaining constant, two parallel lines of hose will have one-fourth the Friction Loss of a single line of the same diameter and length and carrying the same quantity of water. Three lines will have one-ninth the Friction Loss of a single line, and four lines will have one-sixteenth the Friction Loss.
- 4) Use a relay pumping operation. This operation will allow for two or more pumps to move the water at manageable pressures.

TURN TO PAGE 55

$$EP = NP + FL + A (\pm) H$$

If the nozzle pressure is reduced, the discharge will be less; therefore the Friction Loss will decrease. What could happen to the fire stream if this procedure is used to lower the Friction Loss?

- 1) The fire stream will have less velocity but flow will still be effective.

TURN TO PAGE 56

- 2) The fire stream will have less velocity flow and might not be an effective fire stream.

TURN TO PAGE 57

$$EP = NP + FL + A (\pm) H$$

You answered that the fire stream will have less velocity and flow, but will still be effective.

YOU ARE PARTIALLY CORRECT.

The fire stream will have less velocity and flow. But remember, there might not be enough water at sufficient pressure to control the fire.

As a Pump Operator you should only use this procedure when you are sure it won't endanger your firefighter.

TURN TO PAGE 58

$$EP = NP + \mathbf{FL} + A (\pm) H$$

You answered that the fire stream will have less velocity and flow and might not be an effective fire stream.

CORRECT YOU ARE!

However, when using this procedure to reduce Friction Loss, you must be sure it won't endanger your firefighter.

TURN TO PAGE 58

$$EP = NP + FL + A (\pm) H$$

Reducing the size of the nozzle and maintaining the same nozzle pressure reduces the Friction Loss, but also reduces the flow.

What could happen to the fire stream if this procedure is used to lower the Friction Loss?

- 1) The fire stream will have less flow, but will still be effective.

TURN TO PAGE 59

- 2) The fire stream will have less flow, but might not be a desired fire stream.

TURN TO PAGE 60

$$EP = NP + \mathbf{FL} + A (\pm) H$$

You answered, "The fire stream will have less flow, but will still be effective."

WRONG!

How could it still be effective with less flow? With less water, your fire stream has less cooling capacity. Using this procedure to reduce Friction Loss could get your firefighter into trouble, and you must first carefully consider all possible ramifications.

TURN TO PAGE 61

$$EP = NP + \mathbf{FL} + A (\pm) H$$

You answered, "The fire stream will have less flow, but might not be an effective fire stream."

THAT IS CORRECT.

The procedure to reduce Friction Loss is the same as the procedure to reduce nozzle pressure. This procedure also requires careful consideration, before it is used because it can endanger the firefighter manning the nozzle.

TURN TO PAGE 61

$$EP = NP + FL + A (\pm) H$$

FRICTION LOSS FORMULA

Although there are several Friction Loss formulas, the Federal Fire Department has adopted **IFSTA's** formula of **CQ²L** for determining Friction Loss in fire hose. This formula was developed by IFSTA for the lightweight hose and pyrolite couplings that are in use in the fire service today.

The following pages show how to solve the formula and provide you with problems to work on your own.

FRICTION LOSS (FL) = CQ²L

The formula used to determine Friction Loss in hose is CQ²L.

C = Coefficient

Q² = (GPM/100) ²

L = Length of hose/100

Coefficients are fixed or constant values given to each hose, depending on the diameter. They are used as the "C" in the CQ²L formula. The smaller the hose diameter, the greater the friction loss for a given GPM. Therefore, you will see that the coefficient is greater for smaller hose than larger hose.

TURN TO PAGE 62

$$EP = NP + FL + A (\pm) H$$

I. C = Coefficient

Coefficients for Single Lines

1"	=	150.0
1 1/2"	=	24.0
1 3/4"	=	15.5
2 1/2"	=	2.0
4"	=	0.2

Coefficients for Multiple Lines

Two 2 1/2"	=	0.5
Three 2 1/2"	=	0.22
One 4" + One 2 1/2"	=	0.12

II. $Q^2 = (GPM/100)^2$

GPM refers to the amount of water flowing.

Q² is the GPM divided by 100 and then squared.

For example: $Q^2 = (200 \text{ GPM}/100)^2 = (2 \text{ GPM})^2 = 4 \text{ GPM}$

TURN TO PAGE 63

$$EP = NP + FL + A (\pm) H$$

III. L = (Length of line/100)

L is the length of the hoselay divided by 100.

Example:

250 feet of hose, divided by 100 equals 2.5.

$$(250/100) = 2.5$$

Now let's put it all together and work a problem to determine the Friction Loss of a hoselay putting it all together. Assume you have a single 2 ½ inch hoselay, 250 feet, with 250 GPM flowing from the tip or nozzle.

$$FL = CQ^2L$$

$$FL = 2 \times (250/100)^2 \times (250/100)$$

$$FL = 2 \times (2.5)^2 \times 2.5$$

$$FL = 2 \times 6.25 \times 2.5$$

$$FL = 31 \text{ PSI}$$

TURN TO PAGE 64

$$EP = NP + FL + A (\pm) H$$

Solve

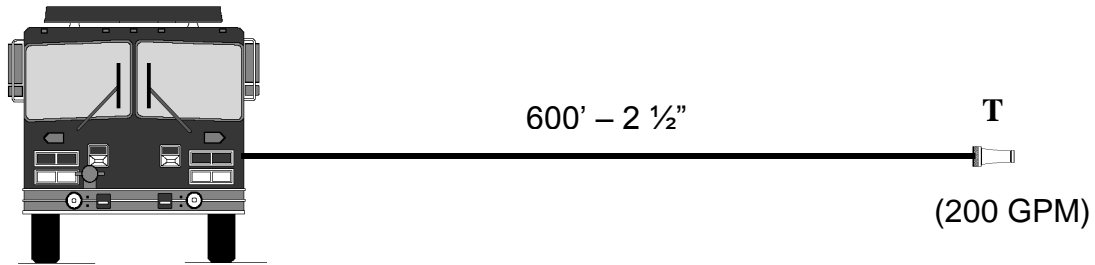

Write in answers

NP = _____

FL = _____

A = _____

$\pm H$ = _____

EP = _____

TURN TO PAGE 65

$$EP = NP + \mathbf{FL} + A (\pm) H$$

If you answered 48 PSI,

YOU ARE CORRECT!

TURN TO PAGE 67

If you did not,

TURN TO PAGE 66 FOR THE CALCULATIONS

$$EP = NP + \mathbf{FL} + A (\pm) H$$

Answer

$$FL = CQ^2L$$

$$FL = C \times (\text{GPM}/100)^2 \times (\text{length of hose}/100)$$

$$FL = 2 \times (200/100)^2 \times (600/100)$$

$$FL = 2 \times (2)^2 \times 6$$

$$FL = 2 \times 4 \times 6$$

$$\mathbf{FL = 48 PSI}$$

TURN TO PAGE 67

$$EP = NP + FL + A (\pm) H$$

DETERMINING FRICTION LOSS FOR APPLIANCES (A)

There is loss of pressure any time an Appliance (**A**) is added to a hoselay. These losses vary widely as they are affected by size, fittings, bends, designs, condition, and rate of flow. Appliance friction loss has to be added to hoselays when computing engine pressure. The following is a list of Appliances and their friction loss, which you should remember and be able to recall when computing hydraulics problems:

1. Forestry Tee	5 PSI
2. Wye/Siamese, water thief	10 PSI
3. Manifolds	10 PSI
4. Portable Monitor	15 PSI
5. Engine – Relay pumping	20 PSI
6. Standpipe	25 PSI (not including head)
7. Ladder Pipe 100 foot E-One	90 PSI (head included)
8. Tele-Squirt 50 feet	65 PSI (head included)

TURN TO PAGE 68

$$EP = NP + FL + A (\pm) H$$

1) Solve

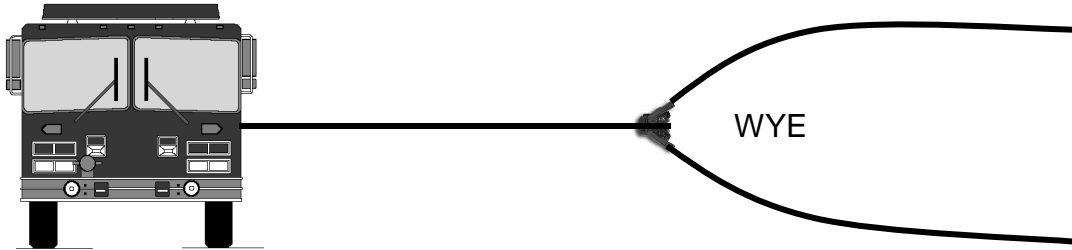

Write in answer for Appliance friction loss (A)

A = _____

TURN TO PAGE 69

$$EP = NP + FL + A (\pm) H$$

1) ANSWER: $A = 10 \text{ PSI}$

Anytime a gated wye is placed in a hoselay, you must add 10 PSI for Appliance friction loss.

2) Solve

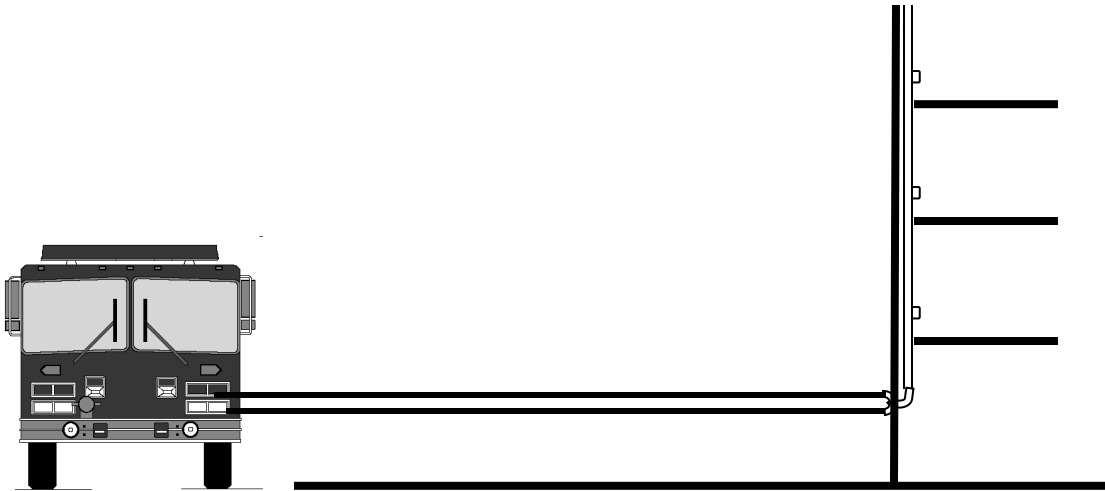

Write in answer for Appliance friction loss (A)

A = _____

TURN TO PAGE 70

$$EP = NP + FL + A (\pm) H$$

2) ANSWER: $A = 25 \text{ PSI}$

When pumping into a standpipe, you must add 25 PSI for Appliance FL. It does not make any difference what the height of the building is; it is always 25 PSI for FL only. This does not include head.

3) Solve

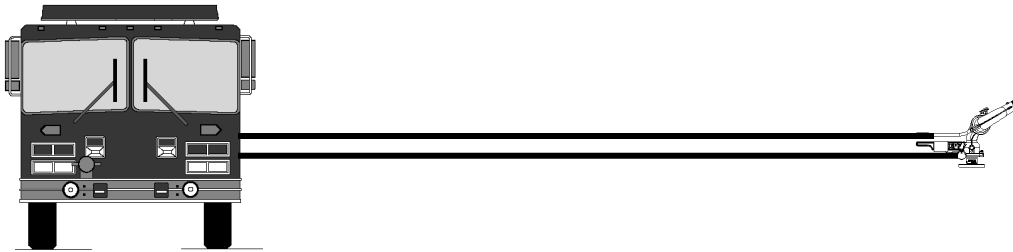

Write in answer for Appliance friction loss (A)

A = _____

TURN TO PAGE 71

$$EP = NP + FL + A (\pm) H$$

3) ANSWER: $A = 15 \text{ PSI}$

With portable monitors you must add 15 PSI for Appliance FL.

4) Solve



Write in answer for Appliance friction loss (A)

A = _____

TURN TO PAGE 72

$$EP = NP + FL + A (\pm) H$$

4) *ANSWER: A = 5 PSI*

With a 1 ½ inch x 1 inch Forestry Tee, you must add 5 PSI for each tee installed in the hoselay.

When you are solving hydraulics problems, you must add in Appliance friction loss. You only have 8 Appliances to remember.

If you are still unsure of how to solve Appliance friction loss, **RETURN TO PAGE 67**

Otherwise,

MOVE ON TO PAGE 73

$$EP = NP + FL + A (\pm) H$$

PRINCIPLES OF HEAD PRESSURE (\pm) H

Head pressure is also called lift, back pressure, gravity loss, or gain. When hose lines are laid up or down or elevations, such as inclines, stairways, fire escapes, canyons, or the face of a building, the pressure loss or gain in pounds per square inch which is exerted by the Head of water must be compensated for.

On hoselays where the nozzle is below the pump, you must subtract head.

On hoselays above the pump, you must add head.

Head is measured in terms of feet of water: One foot of head is equivalent to a column of water one foot high.

Head is pressure; a column of water one foot high by 1 square inch weighs .434 pounds at its base regardless of the size or shape of the vessel it is in. (See illustration)

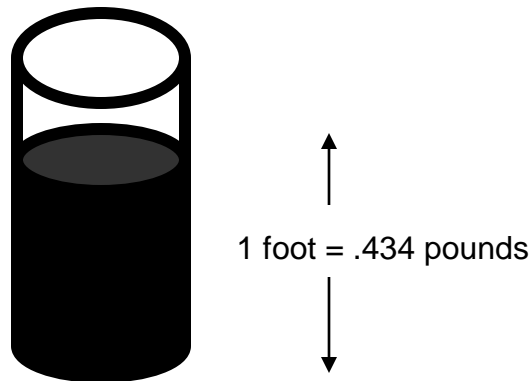

Therefore, for each foot of head, water exerts a pressure of .434 pounds per square inch at the base.

Every 2.3 feet of head develops a pressure of one pound per square inch. **Head pressure is proportional to the height of the liquid column alone, and not to the size or shape of the vessel.**

TURN TO PAGE 74

$$EP = NP + FL + A (\pm) H$$

Head is very much like climbing up or down a ladder. As you climb up a ladder, you must exert strength (pressure) in your legs and arms to reach the desired elevation. When descending a ladder, gravity exerts a pull upon your body. If you lost your footing and fell, your body would gain tremendous downward pressure. The amount of pressure developed would determine the force of impact. The higher the fall in elevation, the greater the pressure.

Let's fill a 5 inch diameter pipe 100 feet high with water. **What is the Head Pressure at the base?**

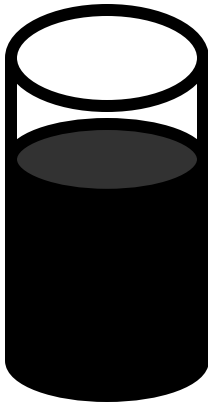

For each foot of head, water exerts a pressure of .434 pounds per square inch at the base. Remember the pressure is proportional to the height of the liquid column alone. Not to the size or shape of the vessel it is in.

TURN TO PAGE 75

$$EP = NP + FL + A (\pm) H$$

To figure the amount of head at the base of the 100 foot pipe you must multiply by .434 PSI because each foot of head creates .434 PSI.

$$\begin{array}{r} 100 \text{ foot pipe} \\ \times .434 \text{ PSI 1 inch of Head} \\ \hline 400 \\ 300 \\ \hline 400 \\ 43.400 \text{ PSI} \end{array}$$

So the 100 foot pipe has 43.4 PSI head at the base of the pipe.

REMEMBER that PSI stands for POUNDS PER SQUARE INCH. Therefore the 5 inch base is not a factor in determining the pressure at the bottom of the pipe.

TURN TO PAGE 76

$$EP = NP + FL + A (\pm) H$$

HEAD PRESSURE MUST BE COMPENSATED FOR BECAUSE:

In hose lays below the pump there is a pressure gain, which could cause the firefighter to lose control of the hose.

In hoselays above the pump the weight of the water is working against the pump. If not compensated for, it could cause insufficient nozzle pressure and an ineffective hose stream.

In computing head, one foot of head either above or below the pump is _____ PSI.

1) .434 PSI

TURN TO PAGE 77

2) .534 PSI

TURN TO PAGE 78

$$EP = NP + FL + A (\pm) H$$

You answered, “.434 PSI for each 1 foot of Head either above or below the pump.”

EXCELLENT!

TURN TO PAGE 79 AND CONTINUE

$$EP = NP + FL + A (\pm) H$$

WRONG

Take enough time here before moving on to remember:

.434 PSI for each 1 foot of Head, either above (+) or below (-) the pump.

TURN TO PAGE 79

$$EP = NP + FL + A (\pm) H$$

When pumping water above the pump, what must you do when calculating engine pressure?

1) Subtract Head.

TURN TO PAGE 80

2) Add Head.

TURN TO PAGE 81

$$EP = NP + FL + A (\pm) H$$

You said head must be subtracted on hosesays pumping water above the pump.
THAT'S INCORRECT. Let's look at it another way.

Assume you are going to run up a steep hill as opposed to running down it. You will exert more energy running up the hill and you will tire easier. So anytime water is being pumped above the pump, you must **add head**.

TURN TO PAGE 82

$$EP = NP + FL + A (\pm) H$$

CORRECT YOU ARE.

Any time water is pumped above the pump, you must **add Head**.

TURN TO PAGE 82

$$EP = NP + FL + A (\pm) H$$

When you are pumping water below the pump, what must you do when calculating engine pressure?

1) Subtract Head.

TURN TO PAGE 83

2) Add Head.

TURN TO PAGE 84

$$EP = NP + FL + A (\pm) H$$

RIGHT ON!

When water is being pumped below the pump, Head must be subtracted.

TURN TO PAGE 85 AND CONTINUE

$$EP = NP + FL + A (\pm) H$$

INCORRECT!!

I think you are having a problem grasping Head Pressure and what to do with it in hydraulics problems.

RETURN TO PAGE 73 AND BEGIN AGAIN

$$EP = NP + FL + A (\pm) H$$

COMPUTING HEAD IN STRUCTURES

For each floor (12 feet) above the pump, add 5 PSI for Head. **Don't add Head for the first floor because the pump is on the same level as the first floor.**

The average distance between floors in buildings is 12 feet. So .434 times 12 is approximately 5 PSI Head per floor. In determining Head for buildings, all you have to remember is **Head equals 5 PSI per floor.**

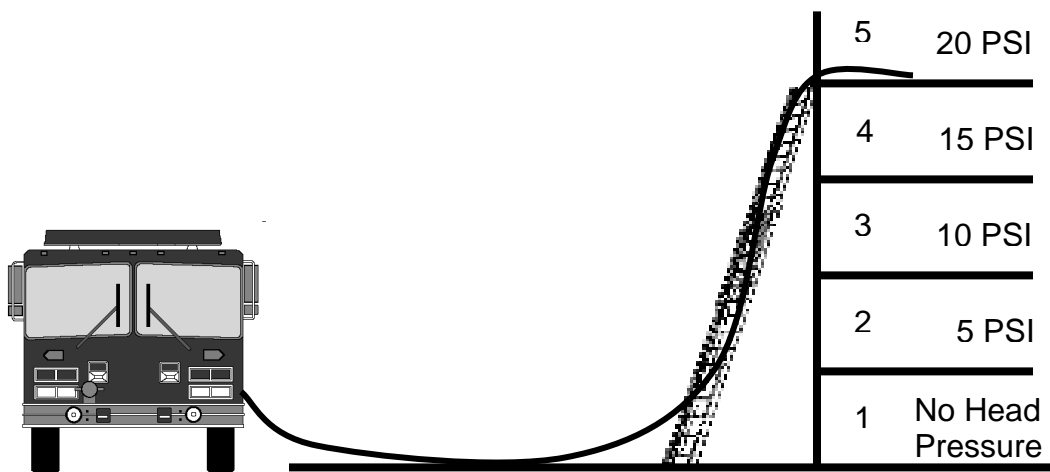

TURN TO PAGE 86

$$EP = NP + FL + A (\pm) H$$

1) Solve

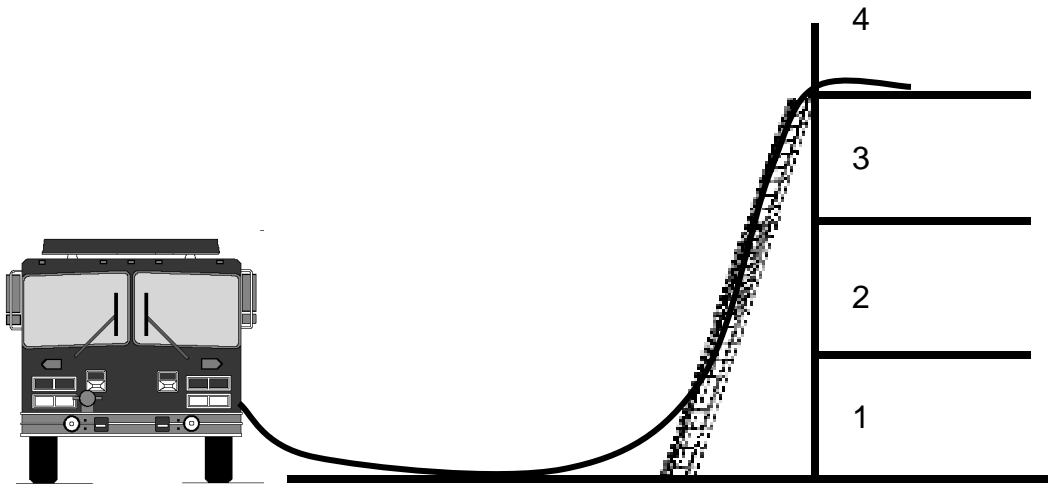

Write in answer for Head ($\pm H$)

$\pm H =$ _____

TURN TO PAGE 87 FOR THE CORRECT ANSWER

$$EP = NP + FL + A (\pm) H$$

1) ANSWER: $H = +15 \text{ PSI}$

In structures you don't add the first floor because the engine is at the same level as the first floor.

2) Solve

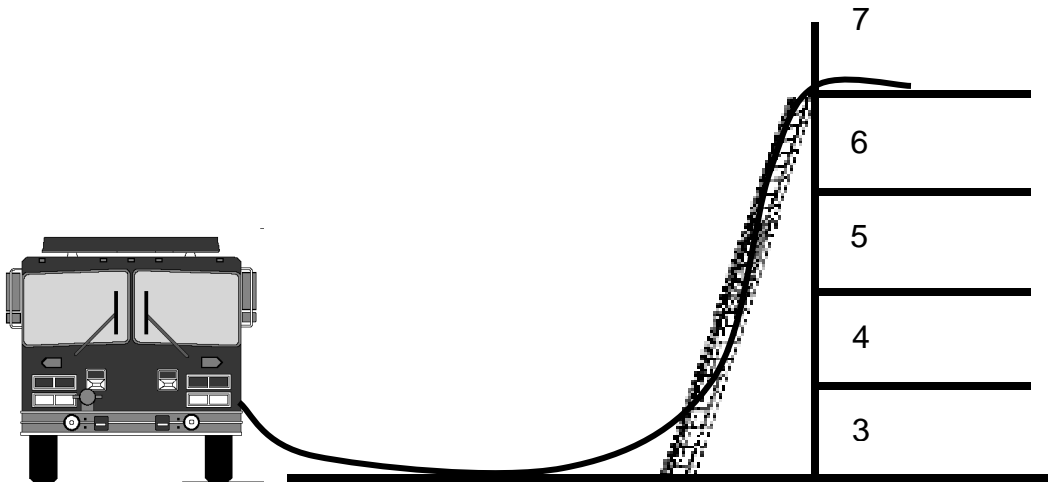

Write in answer for Head ($\pm H$)

$\pm H =$ _____

TURN TO PAGE 88 FOR THE CORRECT ANSWER

$$EP = NP + FL + A (\pm) H$$

2) ANSWER: $H = +30 \text{ PSI}$

Don't add Head for the first floor. Six floors at 5 PSI each equals +30 PSI

3) Solve

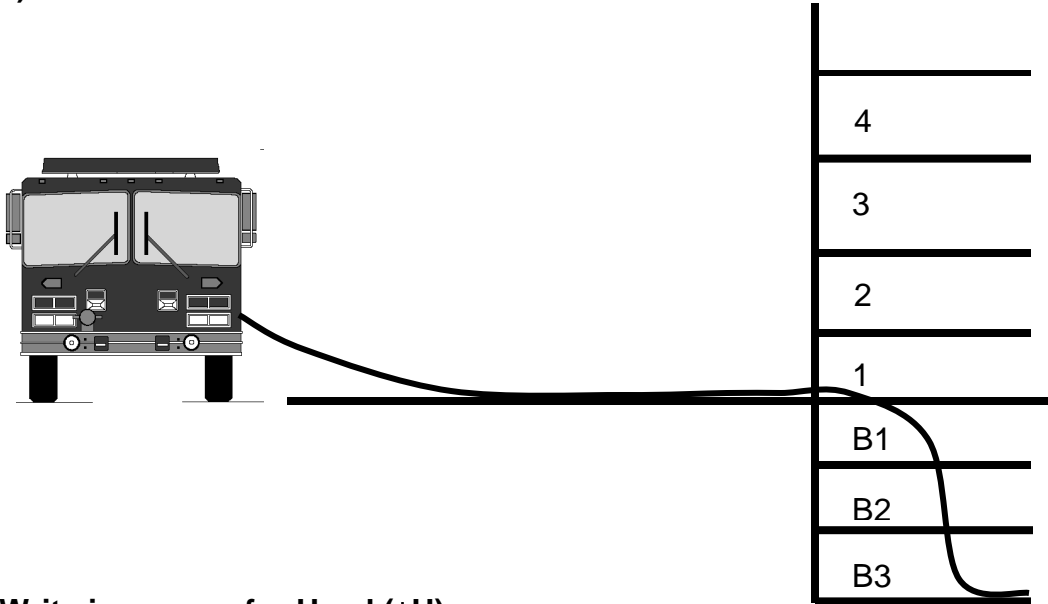

Write in answer for Head ($\pm H$)

$\pm H =$ _____

TURN TO PAGE 89 FOR THE CORRECT ANSWER

$$EP = NP + FL + A (\pm) H$$

3) *ANSWER: H = -15 PSI*

Below the pump you must subtract Head. So three floors below the pump at 5 PSI per floor

If you are having problems computing Head in structures, **RETURN TO PAGE 85 AND BEGIN AGAIN.**

If you answered the Head problems for structures correctly, you are doing great. **TURN TO PAGE 90 AND CONTINUE.**

$$EP = NP + FL + A (\pm) H$$

COMPUTING HEAD FOR WILDLAND HOSELAYS

The most difficult task in computing head for wildland hoselays is estimating elevation changes either above or below the pump. Your estimates will have to be approximate.

You will find that by using increments of 100 feet, 50 feet, or 25 feet, your estimates will be close and all you have to remember are three figures for head.

	ABOVE PUMP	BELOW PUMP
100 feet	+43 PSI	-43 PSI
50 feet	+22 PSI	-22 PSI
25 feet	+11 PSI	-11 PSI

Computing head for wildland hoselays is the same as for structures. Just remember that any time the hoselay is above the pump, you must add Head, and any time that it is below the pump, you must subtract head. The figures for wildland hoselays that are given above will be used throughout the rest of the text. The figure of 5 PSI per floor that is used for structure fires should not be used for test purposes or when working a wildland problem.

TURN TO PAGE 91

$$EP = NP + FL + A (\pm) H$$

1) Solve

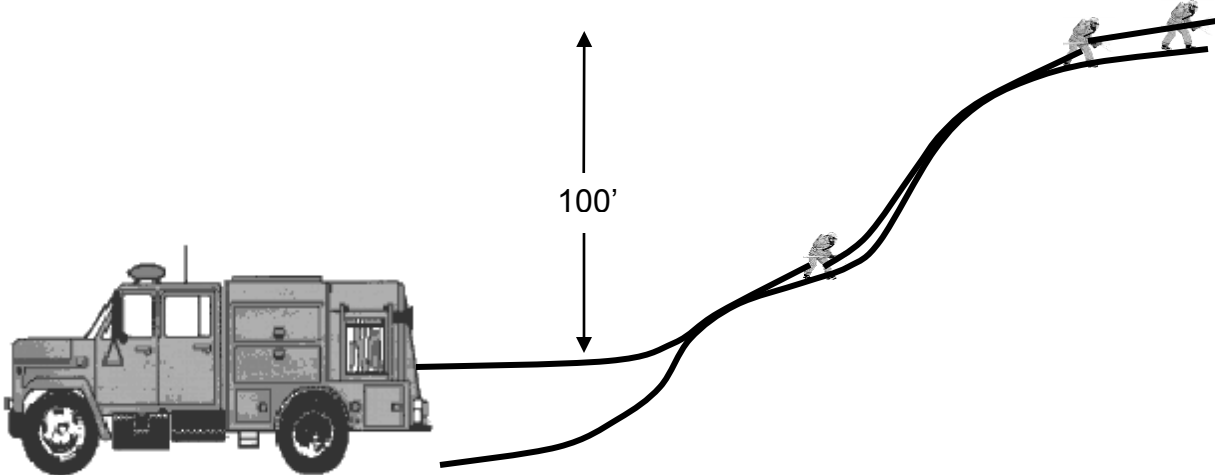

Write in answer for Head ($\pm H$)

$\pm H =$ _____

TURN TO PAGE 92 FOR THE CORRECT ANSWER

$$EP = NP + FL + A (\pm) H$$

1) ANSWER: $H = +43 \text{ PSI}$

Above the pump you must add Head, 100 feet is +43 PSI.

2) Solve

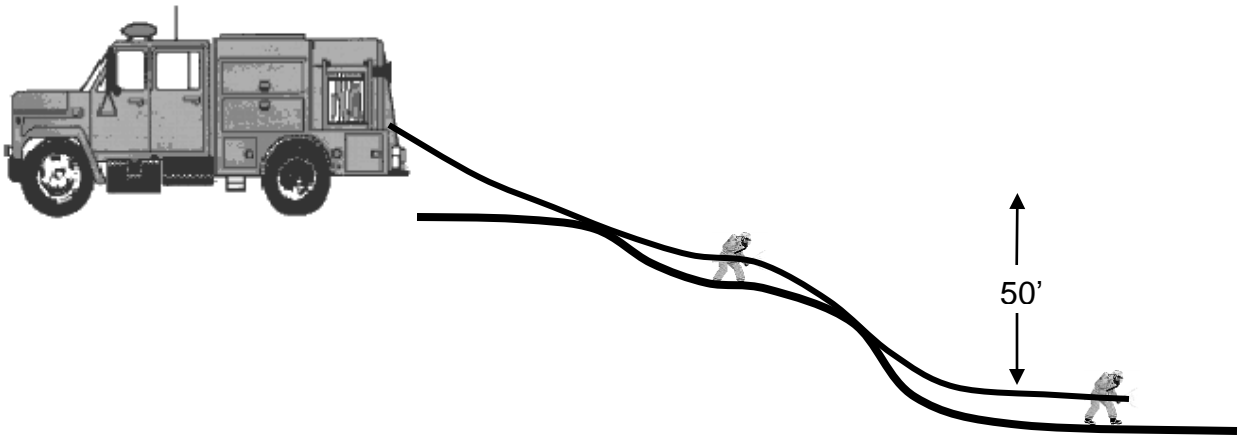

Write in the answer for Head ($\pm H$)

$\pm H =$ _____

TURN TO PAGE 93 FOR THE CORRECT ANSWER

$$EP = NP + FL + A (\pm) H$$

2) ANSWER: $H = -22 \text{ PSI}$

Below the pump you must subtract Head, 50 feet of elevation below the pump equals -22 PSI Head pressure.

3) Solve

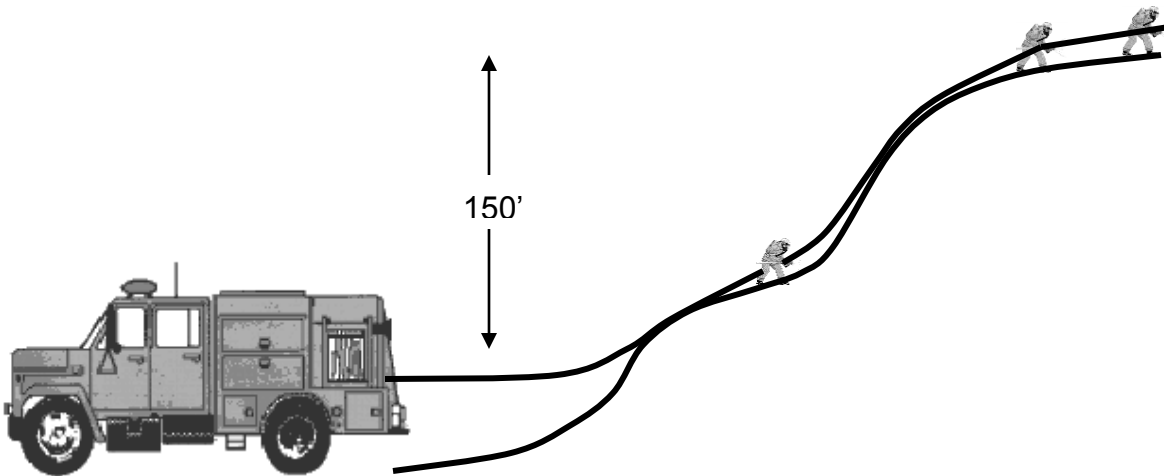

Write in answer for Head ($\pm H$)

$\pm H =$ _____

TURN TO PAGE 94 FOR THE CORRECT ANSWER

$$EP = NP + FL + A (\pm) H$$

3) ANSWER: $H = +65 \text{ PSI}$

Above the pump you must add Head, 150 feet of elevation above the pump x .434 PSI/foot = +65 PSI.

4) Solve

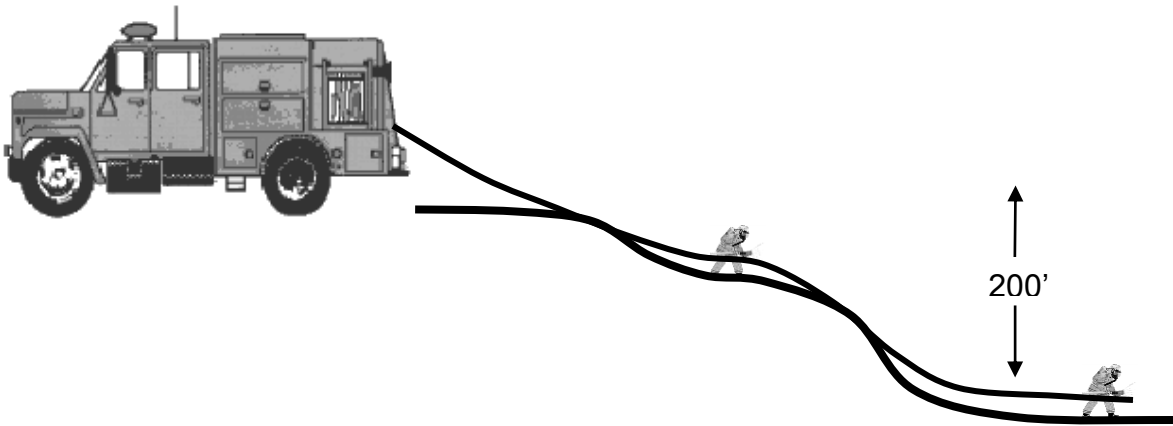

Write in answer for Head ($\pm H$)

$\pm H =$ _____

TURN TO PAGE 95 FOR THE CORRECT ANSWER

$$EP = NP + FL + A (\pm) H$$

4) *ANSWER: H = - 86 PSI*

Below the pump you must subtract head. 100 feet is 43 PSI, and because it is a total of 200 feet, the total head pressure equals 2 x 43 or -86 PSI

If you are having problems with head in wildland hoselays, **RETURN TO PAGE 90 AND BEGIN AGAIN.**

If you answered all the head problems for wildland hoselays correctly, you are doing fine.

TURN TO PAGE 96 AND CONTINUE.

$$EP = NP + FL + A (\pm) H$$

CHAPTER II SUMMARY

1) NOZZLE PRESSURE (NP)

Nozzle Pressure is the amount of pressure required to make the nozzle operate effectively and must be added in to the problem when you are computing hydraulics problems.

Remember that we standardized terminology for nozzles. **Tips** produce a solid stream and **combination nozzles** produce fog streams.

Standard Nozzle Pressures

Tips

NP 50 PSI	Hand Held Tip
NP 80 PSI	Master Stream Appliance Tip

Combination Nozzles

NP 100 PSI	Hand Held Fog Nozzle
NP 100 PSI	Master Stream Fog Nozzle

2) FRICTION LOSS (FL)

When two items rub together there is a loss of energy caused by friction. This also applies to water rubbing on the interior surface of the fire hose. In order to produce effective fire streams, the amount of Friction Loss in the hose, between the engine and nozzle, must be calculated and compensated for.

The smaller the diameter of hose, the more Friction Loss involved. The larger the diameter of hose, the less Friction Loss involved.

Friction Loss is computed per 100 foot lengths of hose whether the hose is laid straight out from the pump uphill or downhill.

CONTINUE TO PAGE 97

$$EP = NP + FL + A (\pm) H$$

The formula for computing friction loss in hose is $FL = CQ^2L$

C = Coefficient for number and diameter of hose

$Q^2 = (GPM/100)^2$

L = (length of hose/100)

C = COEFFICIENT

Single Lines	<u>Diameter</u>	=	<u>Coefficient</u>
	1"	=	150.0
	1 1/2"	=	24.0
	1 3/4"	=	15.5
	2 1/2"	=	2.0
	4"	=	0.2
Multiple Lines	<u>Diameter</u>	=	<u>Coefficient</u>
	Two 2 1/2"	=	0.5
	Three 2 1/2"	=	0.22
	One 4" + One 2 1/2"	=	0.12

$Q^2 = (GPM/100)^2$

Q^2 is the GPM flowing from a tip or nozzle, divided by 100, and then squared.

L = (length of hose/100)

L is the length of the hose divided by 100.

TURN TO PAGE 98

$$EP = NP + FL + A (\pm) H$$

3) REDUCING FRICTION LOSS (FL)

There are four methods of overcoming excessive friction loss in hose lines:

A. Reduce the nozzle pressure. If the nozzle pressure is reduced, the GPM will be less; therefore, the friction loss will decrease.

CAUTION: This may prevent the fire stream from performing the required task.

B. Reduce the size of the nozzle, but maintain the same nozzle pressure. Reducing the nozzle size while maintaining the same nozzle pressure also reduces the GPM.

CAUTION: The quantity of water being discharged might not be sufficient to cool the fire in order to accomplish extinguishment.

C. Lay a parallel hose line or increase the hose size. With all other factors remaining constant, two parallel lines of hose will have one-fourth the friction loss of a single line (same diameter and length) carrying the same quantity of water. Three lines will have one-ninth the friction loss of a single line, and four lines will have one-sixteenth the friction loss.

D. Use a relay pumping operation. This operation will allow for two or more pumps to move the water at manageable pressures.

4) APPLIANCES (A)

There is loss of pressure any time an appliance is added to a hoselay. This loss in pressure (Appliance Friction Loss) must be added to hoselays that have appliances in order to determine the accurate Engine Pressure (EP)

Appliance Friction Loss

1. Forestry Tee (1" x 1 1/2")	5 PSI FL
2. Wye/Siamese, Water Thief	10 PSI FL
3. Portable Monitor	15 PSI FL
4. Engine (relay pumping)	20 PSI FL
5. Stand Pipe	25 PSI FL
6. Ladder Pipe 100 foot E-One	90 PSI FL (head included)
7. Tele-Squirt 50 feet	65 PSI FL (head included)

TURN TO PAGE 99

$$EP = NP + FL + A (\pm) H$$

5) HEAD (\pm H)

Head is also called lift, back pressure, gravity loss, or gain. When hose lines are laid up or down an elevation such as inclines, stairways, fire escapes, canyons or the face of a building, the pressure loss or gain in pounds per square inch which is exerted by the Head of water, must be compensated for. On hoselays where the nozzle is **below** the pump you must **subtract** Head. On hoselays **above** the pump you must **add** Head.

Computing Head for Structures

For each floor (12 feet) above the pump, add 5 PSI for Head. Do not add Head for the first floor because the pump is on the same level as the first floor.

Computing Head For Wildland Hoselays

Use increments of 100 feet, 50 feet, or 25 feet.

	ABOVE PUMP	BELOW PUMP
100 feet	+43 PSI	-43 PSI
50 feet	+22 PSI	-22 PSI
25 feet	+11 PSI	-11 PSI

TURN TO PAGE 100 AND LEARN HOW TO USE THE FHRS

CHAPTER III

DETERMINING NOZZLE REACTION

1.57 d² NP

.505 x GPM

1.57 d² NP

.505 x GPM

When water flows through a nozzle at a given pressure, a force on the backside of the nozzle is transformed into water velocity as the water moves through the nozzle. This counterforce, known as **Nozzle Reaction** illustrates Issac Newton's third law of motion. This law states that for every action there is an equal and opposite reaction. Therefore, the greater the nozzle discharge pressure, the greater the **Nozzle Reaction**.

It is the **Nozzle Reaction** that limits the amount of nozzle pressure that can be supplied to an attack line. Fire attack can be hampered, equipment can be damaged, and most importantly personnel can be injured by excessive nozzle reaction.

TURN TO PAGE 102

1.57 d² NP

.505 x GPM

When water flows through a nozzle at a given pressure, a force on the backside of the nozzle is created. What is this called?

1) Nozzle Velocity

TURN TO PAGE 103

2) Nozzle Reaction

TURN TO PAGE 103

1.57 d² NP

.505 x GPM

If you answered Nozzle Velocity,

YOU ARE INCORRECT.

If you answered Nozzle Reaction,

YOU ARE CORRECT!

Remember that Nozzle Reaction is the counterforce created when water is discharged out of a nozzle. Nozzle Reaction is the single biggest factor that limits the amount of nozzle pressure.

TURN TO PAGE 104

1.57 d² NP

.505 x GPM

The amount of Nozzle Reaction experienced during hose line operations depends upon the type of nozzle being used. Combination nozzles have greater nozzle reactions than solid streams. This is because they are primarily operated at higher nozzle pressures.

To calculate the amount of Nozzle Reaction in a straight tip nozzle (TIP), use the formula:

$$\text{NR} = 1.57 \text{ d}^2 \text{ NP}$$

To calculate the amount of Nozzle Reaction in a combination nozzle, use the formula:

$$\text{NR} = .505 \text{ x GPM}$$

TURN TO PAGE 105

1.57 d² NP

.505 x GPM

The amount of Nozzle Reaction experienced during hose line operations depends upon the type of nozzle being used. A _____ has greater nozzle pressure than a _____.

- 1) Combination Nozzle, Straight Tip

TURN TO PAGE 107

- 2) Straight Tip, Combination Nozzle

TURN TO PAGE 106

1.57 d² NP

.505 x GPM

You answered that a Straight Tip has a greater nozzle pressure than a Combination Nozzle.

YOU ARE INCORRECT.

Remember that combination nozzles are normally pumped at higher pressure and will have a higher Nozzle Reaction.

If you are having difficulties understanding Nozzle Reaction, **TURN TO PAGE 101** and review.

1.57 d² NP

.505 x GPM

You answered that a combination nozzle has a greater nozzle pressure than a straight tip.

YOU ARE CORRECT!

TURN TO PAGE 108

1.57 d² NP

.505 x GPM

To calculate the amount of Nozzle Reaction in a Straight Tip, use the formula:

$$\mathbf{NR = 1.57 d^2 NP}$$

NR = Nozzle Reaction in Pounds
1.57 = A Constant
d² = Nozzle diameter in inches squared
NP = Nozzle Pressure in PSI

To calculate the amount of Nozzle Reaction in a combination nozzle, use the formula:

$$\mathbf{NR = .505 x GPM}$$

NR = Nozzle Reaction in Pounds
.505 = A Constant
GPM = Gallons Per Minute

TURN TO PAGE 109

1.57 d² NP

.505 x GPM

1) Solve

Determine the **Nozzle Reaction** of a hose line equipped with a 1 inch tip operating at a nozzle pressure of 50 PSI.

NR = 1.57 d² NP

NR = 1.57 _____

NR = _____

TURN TO PAGE 110

1.57 d² NP

.505 x GPM

1) *ANSWER: NR = 78.5 Pounds*

2) Solve

Determine the **Nozzle Reaction** of a hose line equipped with a combination nozzle operating at a nozzle pressure of 100 PSI, and flowing 250 GPM.

NR = .505 x GPM

NR = _____

TURN TO PAGE 111

1.57 d² NP

.505 x GPM

2) *ANSWER: NR = 126.25 Pounds*

3) Solve

Determine the **Nozzle Reaction** of a hose line equipped with a ¾ inch tip operating at a nozzle pressure of 50 PSI.

NR = 1.57 d² NP

NR = 1.57 _____

NR = _____

TURN TO PAGE 112

1.57 d² NP

.505 x GPM

3) *ANSWER: NR = 44.15 Pounds*

4) Solve

Determine the **Nozzle Reaction** of a master stream equipped with a combination nozzle operating at a nozzle pressure of 100 PSI and flowing 1000 GPM.

NR = .505 x GPM

NR = _____

TURN TO PAGE 113

1.57 d² NP

.505 x GPM

4) *ANSWER: NR = 505 Pounds*

**CHAPTER III
SUMMARY**

1) NOZZLE REACTION (NR)

When water flows through a nozzle at a given pressure, a force on the backside of the nozzle is transformed into water velocity as the water moves through the nozzle. This counterforce, known as **Nozzle Reaction** illustrates Issac Newton's third law of motion. This law states that for every action there is an equal and opposite reaction. Therefore, the greater the nozzle discharge pressure, the greater the **Nozzle Reaction**.

It is the **Nozzle Reaction** that limits the amount of nozzle pressure that can be supplied to an attack line. Fire attack can be hampered, equipment can be damaged, and most importantly personnel can be injured by excessive nozzle reaction.

2) CALCULATING NOZZLE REACTION (NR)

To calculate the amount of **Nozzle Reaction** in a Straight Tip, use the formula:

$$NR = 1.57 d^2 NP$$

NR = Nozzle Reaction in Pounds
1.57 = A Constant
d² = Nozzle diameter in inches squared
NP = Nozzle Pressure in PSI

To calculate the amount of **Nozzle Reaction** in a combination nozzle, use the formula:

$$NR = .505 x GPM$$

NR = Nozzle Reaction in Pounds
.505 = A Constant
GPM = Gallons Per Minute

TURN TO PAGE 114

CHAPTER IV



RELAY PUMPING OPERATIONS

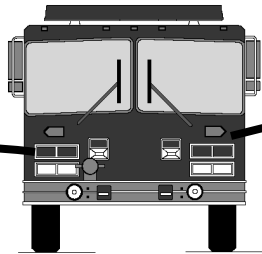

FRICITION LOSS + ELEVATION + INTAKE PRESSURE

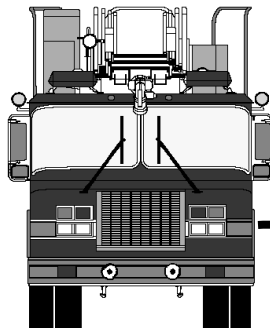

FRICITION LOSS + ELEVATION + INTAKE PRESSURE

Relay Pumping is a pump operation performed to assure adequate flow and to assure that the safety pressure of hose lines is not exceeded. Pump Operators will be required to perform a relay operation when any of the following scenarios develop:

- 1) When the water supply is inadequate for the required flow needed to perform the operation.
- 2) When the pressure requirements to supply the required amount of water are too great for one pumper.
- 3) When the pressure requirements exceed the safe operating limits of the hose lines.

The inability to meet required flow usually occurs when the water source or supply and fire are separated by a long distance. This distance can be a few hundred feet or it can be over a mile in some rural locations. Additionally, due to water main breaks caused by natural disasters, a relay operation may have to be performed to move basic water supplies.

There are several methods that can be used for performing **Relay Pumping**. In all methods used, the Pump Operators must know the following two factors:

1. The required flow to be maintained
2. The length and size of the hose

Additionally, there are two main types of pressure losses that **Relay Pumping** must overcome. These are:

1. Elevation pressure
2. Friction loss in the hose

TURN TO PAGE 116

FRICITION LOSS + ELEVATION + INTAKE PRESSURE

In order to **Relay Pump**, the Pump Operator must know the following two factors:

1) The required flow to be maintained and the length and size of the hose to be supplied.

TURN TO PAGE 118

2) The required pressure at the fire scene and the size of the hose.

TURN TO PAGE 117

FRICITION LOSS + ELEVATION + INTAKE PRESSURE

You answered, "The required pressure at the fire scene and the size if the hose."

YOU ARE INCORRECT.

In order to perform **Relay Pumping**, you must always know the required flow to be maintained and the length and size of the hose to be supplied.

TURN TO PAGE 119 AND CONTINUE.

FRICITION LOSS + ELEVATION + INTAKE PRESSURE

You answered, "The required flow to be maintained and the length and size of the hose to be supplied."

YOU ARE CORRECT!

TURN TO PAGE 119 AND CONTINUE.

FRICITION LOSS + ELEVATION + INTAKE PRESSURE

There are certain limitations to **Relay Pumping**. These limitations are:

Pumpers are rated for a maximum capacity at 150 PSI net pump discharge pressure. If higher pressures are needed, the capacity of the pumper is reduced proportionally.

Pressures are also limited because fire hose should not be used at pressures that exceed annual test pressures.

Intake pressure should never drop below 20 PSI.

TURN TO PAGE 120

FRICTION LOSS + ELEVATION + INTAKE PRESSURE

The relay pumping operation called the “Constant Pressure Method” is primarily used for long distances over flat ground and allows for all pumpers to relay pump the same discharge pressure at all times. This method is not applicable to our area because most of our rural areas are located in hilly and uneven terrain and water supply differs throughout the response.

In order to work in our geographic area, the **Relay Pumping** method to be used by the Federal Fire Department will be a variation of the constant pressure method. This variation does not require the pumpers to be placed at equal lengths, nor does it require water to be wasted by an open discharge draining excessive flow. The variation of the constant pressure method also allows for a pumper to be inserted in any part of the hoselay to make the lay effective.

TURN TO PAGE 121

FRICITION LOSS + ELEVATION + INTAKE PRESSURE

In order to use the variation of the Constant Pressure Method, the Pump Operator will use the following formula:

Required Flow = Friction Loss + Elevation + Intake Pressure.

Example:

At the fire scene, a pumper is supplying a 100 foot (quint) truck, which is flowing 1000 GPM through a combination nozzle. The pumper has laid 500 feet of 4 inch hose. This problem calculates as follows:

$$NP = 100 \text{ PSI}$$

$$FL = 100 \text{ PSI}; 20 \text{ PSI per } 100 \text{ feet.}$$

$$A = 90 \text{ PSI}$$

$$H = 0$$

$$IP = 20 \text{ PSI (min.)}$$

$$EP = 310 \text{ PSI}$$

Since the total pressure exceeds the safety pressure of the hose and is well above the rated capacity of the pump, the pressure must be split between the pumper and the truck. This problem now calculates as follows:

Supply Pump

$$NP = 0 \text{ PSI}$$

$$FL = 100 \text{ PSI}$$

$$A = 0 \text{ PSI}$$

$$H = 0 \text{ PSI}$$

$$IP = 20 \text{ PSI (min.)}$$

$$EP = 120 \text{ PSI}$$

Fire Pump

$$NP = 100 \text{ PSI}$$

$$FL = 0 \text{ PSI}$$

$$A = 90 \text{ PSI}$$

$$H = 0 \text{ PSI}$$

$$IP = 0 \text{ PSI}$$

$$EP = 190 \text{ PSI}$$

TURN TO PAGE 122

FRICITION LOSS + ELEVATION + INTAKE PRESSURE

1) Solve

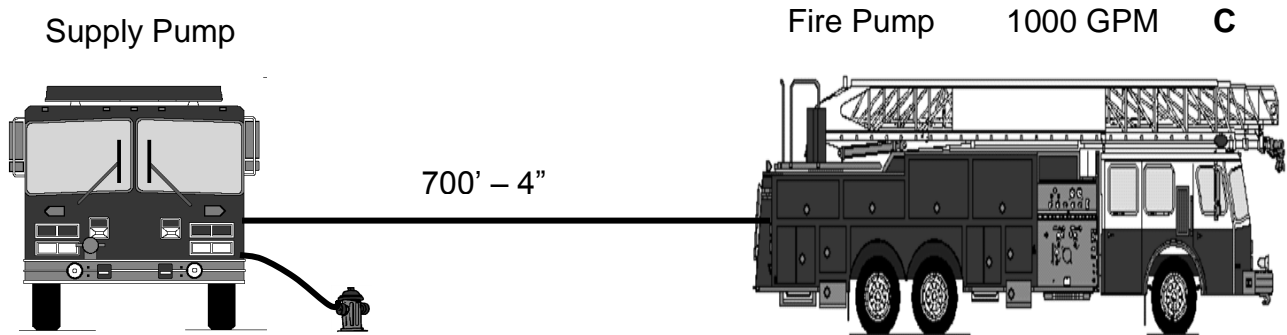

Write in answers

Supply Pump

NP = _____

FL = _____

A = _____

H = _____

IP = _____

EP = _____

Fire Pump

NP = _____

FL = _____

A = _____

H = _____

IP = _____

EP = _____

TURN TO PAGE 123

FRICITION LOSS + ELEVATION + INTAKE PRESSURE

1) ANSWER:

Supply Pump

$$NP = 0 \text{ PSI}$$

$$FL = 140 \text{ PSI}$$

$$A = 0 \text{ PSI}$$

$$H = 0 \text{ PSI}$$

$$IP = 20 \text{ PSI}$$

$$EP = 160 \text{ PSI}$$

Fire Pump

$$NP = 100 \text{ PSI}$$

$$FL = 0 \text{ PSI}$$

$$A = 90 \text{ PSI}$$

$$H = 0 \text{ PSI}$$

$$IP = 0 \text{ PSI}$$

$$EP = 190 \text{ PSI}$$

If you solved this problem correctly, OUTSTANDING! If you had some difficulties with this exercise, **RETURN TO PAGE 121.**

TURN TO PAGE 124

FRICITION LOSS + ELEVATION + INTAKE PRESSURE

2) Solve

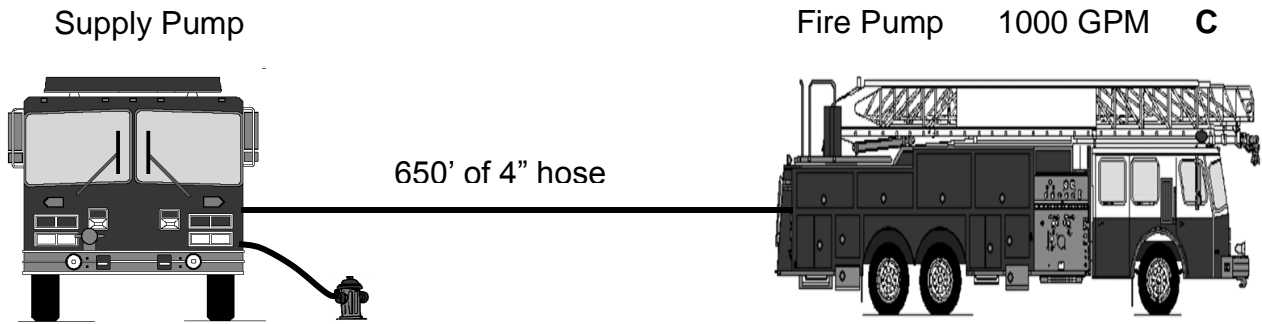

Write in answers

Supply Pump

NP = _____

FL = _____

A = _____

H = _____

IP = _____

EP = _____

Fire Pump

NP = _____

FL = _____

A = _____

H = _____

IP = _____

EP = _____

TURN TO PAGE 125

FRICITION LOSS + ELEVATION + INTAKE PRESSURE

2. ANSWER:

Supply Pump

$$NP = 0 \text{ PSI}$$

$$FL = 130 \text{ PSI}$$

$$A = 0 \text{ PSI}$$

$$H = 0 \text{ PSI}$$

$$IP = 20 \text{ PSI}$$

$$EP = 150 \text{ PSI}$$

Fire Pump

$$NP = 100 \text{ PSI}$$

$$FL = 0 \text{ PSI}$$

$$A = 90 \text{ PSI}$$

$$H = 0 \text{ PSI}$$

$$IP = 0 \text{ PSI}$$

$$EP = 190 \text{ PSI}$$

If you solved this problem correctly, OUTSTANDING! If you had some difficulties with this exercise, **RETURN TO PAGE 121.**

TURN TO PAGE 126

FRICITION LOSS + ELEVATION + INTAKE PRESSURE

3) Solve

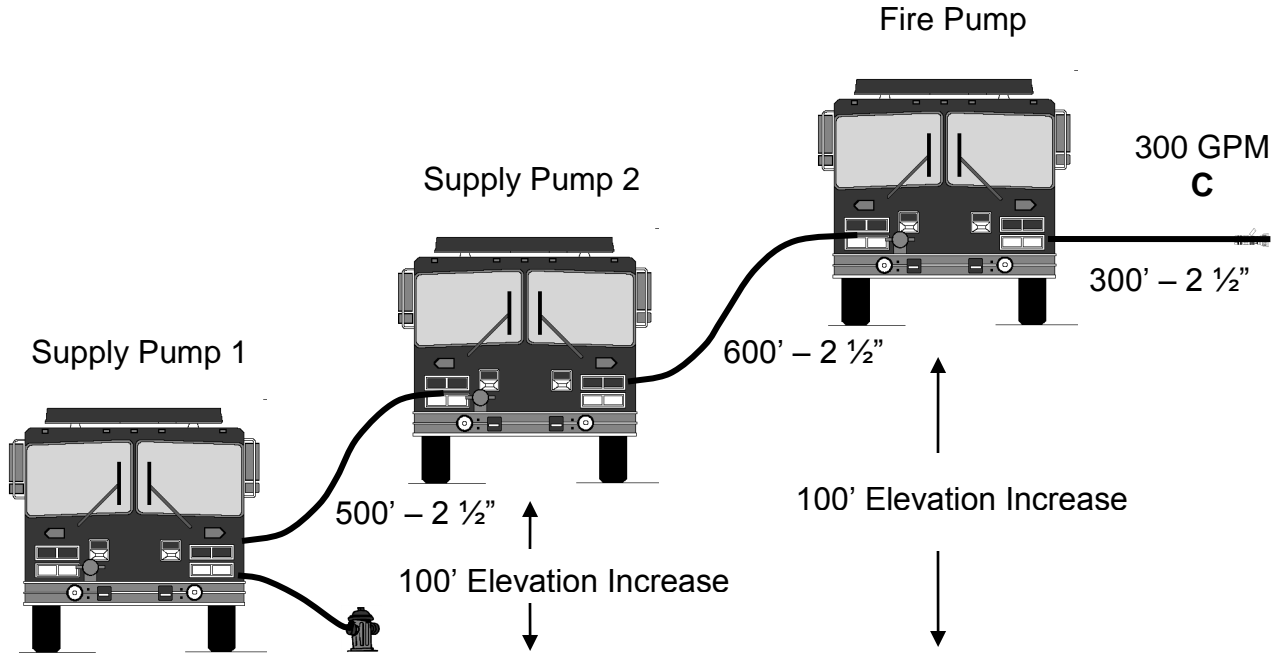

Write in answers

Supply Pump 1

NP = _____

FL = _____

A = _____

H = _____

IP = _____

EP = _____

Supply Pump 2

NP = _____

FL = _____

A = _____

H = _____

IP = _____

EP = _____

Fire Pump

NP = _____

FL = _____

A = _____

H = _____

IP = _____

EP = _____

TURN TO PAGE 127

FRICITION LOSS + ELEVATION + INTAKE PRESSURE

3) ANSWERS:

Supply Pump 1

NP = 0 PSI

FL = 90 PSI

A = _____

H = + 43 PSI

IP = 20 PSI

EP = 153 PSI

Supply Pump 2

NP = 0 PSI

FL = 108 PSI

A = _____

H = + 43 PSI

IP = 20 PSI

EP = 171 PSI

Fire Pump

NP = 100 PSI

FL = 54 PSI

A = _____

H = _____

IP = _____

EP = 154 PSI

TURN TO PAGE 128

FRICITION LOSS + ELEVATION + INTAKE PRESSURE

4) Solve

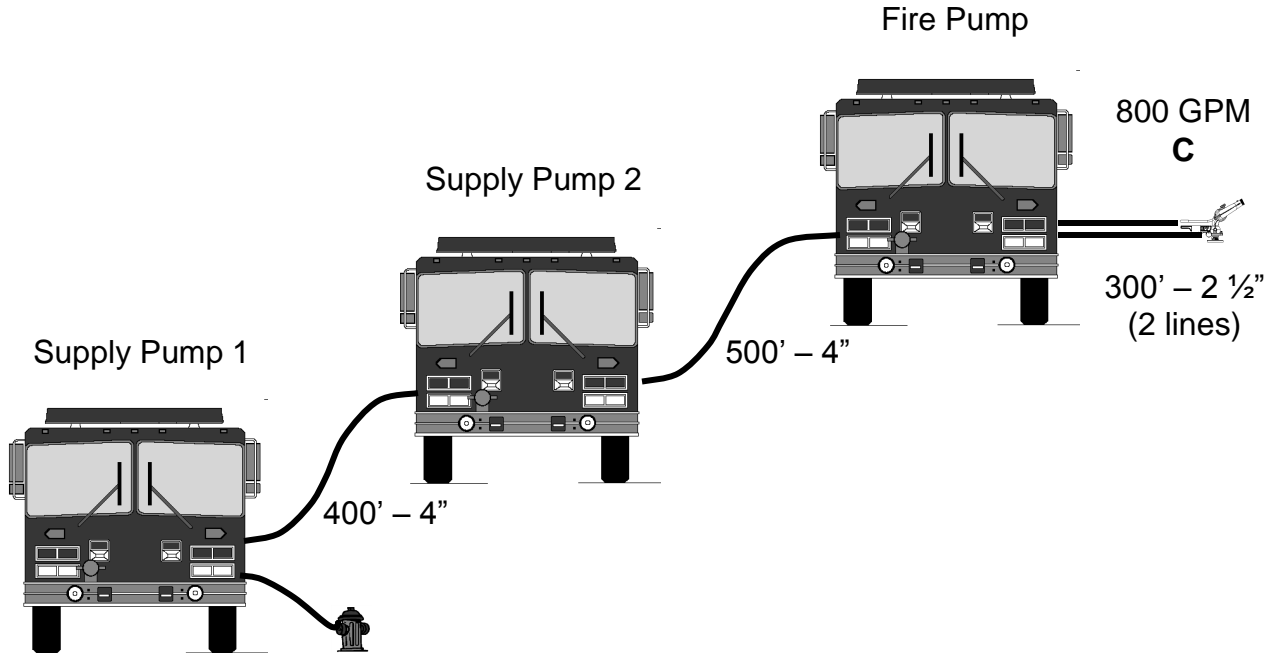

Write in answers

Supply Pump 1

Supply Pump 2

Fire Pump

NP = _____

NP = _____

NP = _____

FL = _____

FL = _____

FL = _____

A = _____

A = _____

A = _____

H = _____

H = _____

H = _____

IP = _____

IP = _____

IP = _____

EP = _____

EP = _____

EP = _____

TURN TO PAGE 129

FRICITION LOSS + ELEVATION + INTAKE PRESSURE

4) ANSWER:

<u>Supply Pump 1</u>	<u>Supply Pump 2</u>	<u>Fire Pump</u>
NP = 0 PSI	NP = 0 PSI	NP = 100 PSI
FL = 51 PSI	FL = 64 PSI	FL = 96 PSI
A = 0 PSI	A = 0 PSI	A = 15 PSI
H = 0 PSI	H = 0 PSI	H = 0 PSI
IP = 20 PSI	IP = 20 PSI	IP = 0 PSI
EP = 71 PSI	EP = 84 PSI	EP = 211 PSI

TURN TO PAGE 130

FRICITION LOSS + ELEVATION + INTAKE PRESSURE

5) Solve

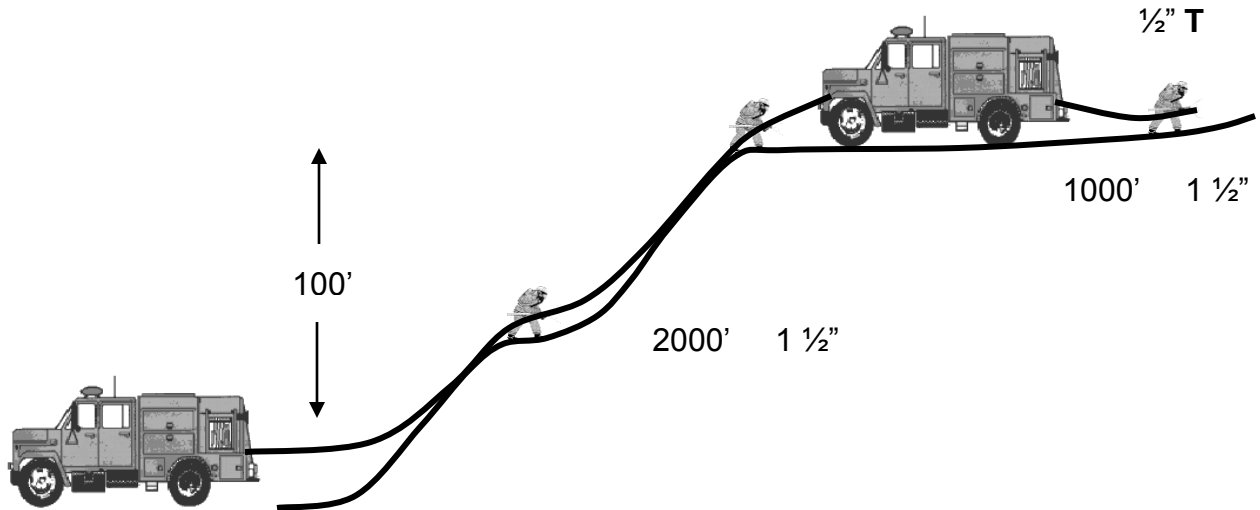

Write in answers

Supply Pump 1

Fire Pump

NP = _____

NP = _____

FL = _____

FL = _____

A = _____

A = _____

H = _____

H = _____

IP = _____

IP = _____

EP = _____

EP = _____

TURN TO PAGE 131

FRICITION LOSS + ELEVATION + INTAKE PRESSURE

5) ANSWER:

Supply Pump 1

NP = 0 PSI

FL = 130 PSI

A = 0 PSI

H = + 43 PSI

IP = 20 PSI

EP = 193 PSI

Fire Pump

NP = 50 PSI

FL = 65 PSI

A = 0 PSI

H = 0 PSI

IP = 0 PSI

EP = 115 PSI

TURN TO PAGE 132

FRICITION LOSS + ELEVATION + INTAKE PRESSURE

CHAPTER IV SUMMARY

1) **Relay Pumping** is a pump operation performed to assure adequate flow and to assure that the safety pressure of hoselines is not exceeded. Pump Operators will be required to perform a relay operation when any of the following scenarios develop:

- A. When the water supply is inadequate for the required flow needed to perform the operation.
- B. When the pressure requirements to supply the required amount of water are too great for one pumper.
- C. When the pressure requirements exceed the safe operating limits of the hose lines.

The inability to meet required flow usually occurs when the water source or supply and fire are separated by a long distance. It could be a few hundred feet or it could be over a mile in some rural locations. Additionally, due to water main breaks caused by natural disasters, a relay operation may have to be performed to move basic water supplies.

There are several methods used for performing **Relay Pumping**. In all methods used, the Pump Operators must know the following two factors:

- A. The required flow to be maintained
- B. The length and size of hose

Additionally, there are two main types of pressure losses that **Relay Pumping** must overcome. These are:

- A. Elevation Pressure
- B. Friction loss in the hose

TURN TO PAGE 133

FRICTION LOSS + ELEVATION + INTAKE PRESSURE

2) The relay pumping operation called the “Constant Pressure Method” is primarily used for long distances over flat ground and allows for all pumpers to relay pump the same discharge pressure at all times. This method is not applicable to our area because most of our rural areas are located in hilly and uneven terrain and water supply differs throughout the response.

In order to work in our geographic areas, the **Relay Pumping** method to be used by the Federal Fire Department will be a variation of the constant pressure method. This variation does not require the pumpers to be placed at equal lengths, nor does it require water to be wasted by an open discharge draining excessive flow. The variation of the constant pressure method also allows for a pumper to be inserted in any part of the hoselay to make the lay effective.

TURN TO PAGE 134

CHAPTER V

FOAM OPERATIONS

CALCULATING FOAM LAYS

**FOAM APPLICATION RATE (FAR)
TOTAL GALLONS PER MINUTE (TGPM)
FOAM CONCENTRATION NEEDED (FCN)
FOAM SOLUTION AVAILABLE (FSA)**

$$\frac{.10 \text{ GPM} \times \text{FSF}}{\text{(FAR)}} \quad \frac{\#N \times \text{SGPM}}{\text{(TGPM)}} \quad \frac{\text{TGPM} \times \%F \times T}{\text{(FCN)}} \quad \frac{\text{FCN} \times 33}{\text{(FSA)}}$$

The purpose of this chapter is to explain the necessary steps that must be performed to provide for a successful foam operation. If foam operations are not performed correctly, foam can be wasted, will not be made correctly, or will not be made at all. The operations explained in this chapter are based on spilled flammable liquids, which are the type of incidents that San Marcos Firefighters would most likely encounter. This chapter identifies the steps that must be taken and understood by the Incident Commander and the Engineer when working with foam.

The first step is to know is the **Foam Application Rate (FAR)**. This tells you the GPM flow you will need to extinguish a certain size of flammable liquid spill. The **Foam Application Rate** for the Federal Fire Department is calculated using the following formula:

$$.10 \text{ GPM} \times \text{FSF} \text{ (fire per square foot)}$$

.10 GPM standard for hydrocarbons= Gallons per minute of foam solution needed per 1 square foot, most likely encountered.

.20 GPM standard for polar solvents= Gallons per minute of foam solution needed per 1 square foot of fire. If polar solvents are involved, use formula **.20 GPM X FSF**.

The second step is to determine the **Total Gallons Per Minute (TGPM)**. This tells you how many GPM's will be used to adequately extinguish the incident. The standard setting for foam operations is 95 GPM for pre-plumbed systems and 120 GPM for in-line eductors with the foam nozzle. Total Gallons Per Minute is calculated using the following formula:

$$\#N \times \text{SGPM}$$

#N = Number of nozzles or in-line eductors needed

SGPM = Standard GPM setting for the nozzle, either 95 GPM or 120 GPM

The third step is to know is the **Foam Concentration Needed (FCN)**. This tells you how much foam concentration you will need to have available to operate over a set period of time. The foam concentration needed is calculated using the following formula:

$$\text{TGPM} \times \%F \times T$$

TGPM = Total Gallons Per Minute and is found by calculating the (#N x SGPM)

% F = Percent of foam being used (In most cases this will be 3%.)

T = Time needed to operate (This will be a minimum of fifteen minutes, but could be longer.)

$$\frac{.10 \text{ GPM} \times \text{FSF}}{(\text{FAR})} \times \frac{\#N \times \text{SGPM}}{(\text{TGPM})} \times \frac{\text{TGPM} \times \%F \times T}{(\text{FCN})} \times \frac{\text{FCN} \times 33}{(\text{FSA})}$$

The fourth step is to understand the **Foam Solution Available (FSA)**. This tells you how much solution you will have available once you have determined the FCN. The formula for **Foam Solution Available** is:

$$\text{FCN} \times 33$$

FCN = Foam Concentration Needed

33 = A constant (It represents the amount of water needed to mix with the FCN)

TURN TO PAGE 137

$$\frac{.10 \text{ GPM} \times \text{FSF}}{(\text{FAR})} \quad \frac{\#N \times \text{SGPM}}{(\text{TGPM})} \quad \frac{\text{TGPM} \times \%F \times T}{(\text{FCN})} \quad \frac{\text{FCN} \times 33}{(\text{FSA})}$$

Calculating Foam Application Rate

In order to further understand these formulas and how they relate to the proper application of foam, each one will be covered in detail. The first calculation we will work with is the **Foam Application Rate (FAR)**. The FAR is used to determine the amount of Foam Solution in GPM that would need to be provided to extinguish a flammable liquid spill. Unlike water, there is not a continuous availability of foam. If foam solution is applied prior to having enough available for complete extinguishment, the foam solution will be wasted and the fire will not be extinguished.

Consider the following examples:

Example 1 pre-plumbed: A flammable liquid spill has ignited and is covering a surface area of approximately 950 square feet. By using the formula **.10 GPM x FSF** the GPM flow needed to extinguish this incident can be properly calculated. In this case the problem calculates as follows:

$$\begin{aligned} &.10 \text{ GPM} \times \text{FSF} \\ &.10 \text{ GPM} \times 950 \text{ SF.} \\ &.10 \text{ GPM} \times 950 \text{ SF} = 95 \text{ GPM} \end{aligned}$$

Example 2 in-line eductor: A flammable liquid spill has ignited and is covering a surface area of approximately 1200 square feet. By using the formula **.10 GPM x FSF** the GPM flow needed to extinguish this incident can be properly calculated. In this case the problem calculates as follows:

$$\begin{aligned} &.10 \text{ GPM} \times \text{FSF} \\ &.10 \text{ GPM} \times 1200 \text{ SF.} \\ &.10 \text{ GPM} \times 1200 \text{ SF} = 120 \text{ GPM} \end{aligned}$$

In the above listed examples, the figures must now be compared to the foam equipment available. In example 1, knowing that the fire can be extinguished with 95 GPM, one pre-plumbed line with a 1 1/2" TFT nozzle and Thunderfog attachment can extinguish this fire. In example 2, knowing that the fire can be extinguished with 120 GPM, one Angus FD450H nozzle (rated at 120 GPM) and one Angus IND 450 in-line eductor can extinguish this fire.

NOTE: *The calculations will not always work out perfect as listed in the examples. To determine the proper GPM personnel will need to divide the Foam Application rate by the Standard GPM setting and round up to the next whole number. More will be covered in Calculating Total Gallons Per Minute on page 142.*

TURN TO PAGE 138

$$\begin{array}{cccc}
 \mathbf{.10 \text{ GPM} \times \text{FSF}} & \mathbf{\#N \times \text{SGPM}} & \mathbf{\text{TGPM} \times \%F \times T} & \mathbf{\text{FCN} \times 33} \\
 \text{(FAR)} & \text{(TGPM)} & \text{(FCN)} & \text{(FSA)}
 \end{array}$$

1) Solve

Determine the required GPM and the number of eductors/nozzles needed for a flammable liquid spill that is covering a surface area of 1700 square feet.

$$.10 \text{ GPM} \times \text{FSF}$$

$$.10 \text{ GPM} \times \underline{\hspace{2cm}} \text{ SF.}$$

$$.10 \text{ GPM} \times \underline{\hspace{2cm}} \text{ SF} = \underline{\hspace{2cm}} \text{ GPM}$$

 GPM will be needed to extinguish this fire.

 Nozzles needed to extinguish this fire, 95 GPM setting.

 Nozzles/Eductors needed to extinguish this fire, 120 GPM setting.

TURN TO PAGE 139

$$\begin{matrix} .10 \text{ GPM} \times \text{FSF} & \#N \times \text{SGPM} & \text{TGPM} \times \%F \times T & \text{FCN} \times 33 \\ \text{(FAR)} & \text{(TGPM)} & \text{(FCN)} & \text{(FSA)} \end{matrix}$$

1) ANSWER

170 GPM will be needed to extinguish this fire.

Two Nozzles will be needed to extinguish this fire at 95 GPM.

Two Nozzles/Eductors will be needed to extinguish this fire at 120 GPM.

2) Solve

Determine the required GPM and the number of eductors/nozzles needed for a flammable liquid spill that is covering a surface area of 2700 square feet.

$$.10 \text{ GPM} \times \text{FSF}$$

$$.10 \text{ GPM} \times \text{_____ SF.}$$

$$.10 \text{ GPM} \times \text{_____ SF} = \text{_____ GPM.}$$

_____ GPM will be needed to extinguish this fire.

_____ Nozzles needed to extinguish this fire, 95 GPM setting.

_____ Nozzles/Eductors needed to extinguish this fire, 120 GPM setting.

TURN TO PAGE 140

$$\begin{array}{cccc} \mathbf{.10 \text{ GPM} \times \text{FSF}} & \mathbf{\#N \times \text{SGPM}} & \mathbf{\text{TGPM} \times \%F \times T} & \mathbf{\text{FCN} \times 33} \\ \text{(FAR)} & \text{(TGPM)} & \text{(FCN)} & \text{(FSA)} \end{array}$$

2) ANSWER

270 GPM will be needed to extinguish this fire.

Three Nozzles will be needed to extinguish this fire at 95 GPM.

Three Nozzles/Eductors will be needed to extinguish this fire at 120 GPM.

3) Solve

Determine the required GPM and the number of eductors/nozzles needed for a flammable liquid spill that is covering a surface area of 4500 square feet.

.10 GPM x FSF.

.10 GPM x _____ SF.

.10 GPM x _____ SF = _____ GPM.

_____ GPM needed to extinguish this fire.

_____ Nozzles needed to extinguish this fire, 95 GPM setting.

_____ Nozzles/Eductors needed to extinguish this fire, 120 GPM setting.

TURN TO PAGE 141

.10 GPM x FSF **#N x SGPM** **TGPM x %F x T** **FCN x 33**
(FAR) (TGPM) (FCN) (FSA)

3) *ANSWER*

450 GPM will be needed to extinguish this fire.

Five Nozzles will be needed to extinguish this fire at 95 GPM.

Four Nozzles/Eductors will be needed to extinguish this fire at 120 GPM.

If you are having difficulty calculating **Foam Application Rate** please **TURN TO PAGE 137 AND START OVER**. If you understand how to calculate the **FAR**, **TURN TO PAGE 142 AND CONTINUE**.

$$\frac{.10 \text{ GPM} \times \text{FSF}}{(\text{FAR})} \quad \frac{\#N \times \text{SGPM}}{(\text{TGPM})} \quad \frac{\text{TGPM} \times \%F \times T}{(\text{FCN})} \quad \frac{\text{FCN} \times 33}{(\text{FSA})}$$

Calculating Total Gallons Per Minute

In order to determine the amount of **Total Gallons Per Minute (TGPM)**, the amount of GPM's that will be used to extinguish this incident, use the following formula:

$$\#N \times \text{SGPM}$$

Where:

#N = Number of nozzles or in-line eductors to extinguish this fire. *Calculated by dividing the Foam Application rate by the Standard GPM setting and round up to the next whole number.*

SGPM = The standard setting of the nozzle you are using, either 95 GPM pre-plumbed line or 120 GPM in-line eductor.

Consider the following examples:

Example 1 pre-plumbed: A flammable liquid spill has ignited and is covering a surface area of approximately 1500 square feet. By using the formula **.10 GPM x FSF** the GPM flow needed to extinguish this incident is calculated to be 150 GPM. Two (2) 95 GPM nozzles will be needed to adequately control this incident, since one does not produce enough flow for the calculated FAR. In order to determine the total gallons per minute that will be flowing, use the formula **#N x SGPM**.

$$\#N \times \text{SGPM}$$

$$2 \times 95$$

190 gallons per minute will be needed to combat this incident.

Example 2 in-line eductor: A flammable liquid spill has ignited and is covering a surface area of approximately 2000 square feet. By using the formula **.10 GPM x FSF** the GPM flow needed to extinguish this incident is calculated to be 200 GPM. Two (2) 120 GPM eductors will be needed to adequately control this incident, since one does not produce enough flow for the calculated FAR. In order to determine the total gallons per minute that will be flowing, use the formula **#N x SGPM**.

$$\#N \times \text{SGPM}$$

$$2 \times 120$$

240 gallons per minute will be needed to combat this incident.

NOTE: *To ensure adequate flow, the number of nozzles or in-line eductors has to round up to the next whole number, since standard flows are not changed.*

TURN TO PAGE 143

$$\frac{.10 \text{ GPM} \times \text{FSF}}{(\text{FAR})} = \frac{\#N \times \text{SGPM}}{(\text{TGPM})} = \frac{\text{TGPM} \times \%F \times T}{(\text{FCN})} = \frac{\text{FCN} \times 33}{(\text{FSA})}$$

1) Solve

Determine the amount of TGPM for an incident that has a FAR of 270 GPM.

Pre-plumbed line:

#N x SGPM

_____ x _____

_____ gallons per minute will be used to combat this incident.

In-line educator:

#N x SGPM

_____ x _____

_____ gallons per minute will be used to combat this incident.

TURN TO PAGE 144

$$\frac{.10 \text{ GPM} \times \text{FSF}}{(\text{FAR})} \quad \frac{\#N \times \text{SGPM}}{(\text{TGPM})} \quad \frac{\text{TGPM} \times \%F \times T}{(\text{FCN})} \quad \frac{\text{FCN} \times 33}{(\text{FSA})}$$

1) ANSWER

285 gallons per minute will be used to combat this incident at 95 GPM, three lines.

360 gallons per minute will be used to combat this incident at 120 GPM, three in-line eductors.

2) Solve

Determine the amount of TGPM for an incident that has a FAR of 360 GPM.

Pre-plumbed line:

#N x SGPM

_____ x _____

_____ gallons per minute will be used to combat this incident.

In-line educator:

#N x SGPM

_____ x _____

_____ gallons per minute will be used to combat this incident.

TURN TO PAGE 145

$$\frac{.10 \text{ GPM} \times \text{FSF}}{(\text{FAR})} \quad \frac{\#N \times \text{SGPM}}{(\text{TGPM})} \quad \frac{\text{TGPM} \times \%F \times T}{(\text{FCN})} \quad \frac{\text{FCN} \times 33}{(\text{FSA})}$$

2) ANSWER

380 gallons per minute will be used to combat this incident at 95 GPM, four lines.

360 gallons per minute will be used to combat this incident at 120 GPM, three in-line eductors.

3) Solve

Determine the amount of TGPM for an incident that has a FAR of 190 GPM.

Pre-plumbed line:

#N x SGPM

_____ x _____

_____ gallons per minute will be used to combat this incident.

In-line educator:

#N x SGPM

_____ x _____

_____ gallons per minute will be used to combat this incident.

TURN TO PAGE 146

$$\begin{array}{cccc} \mathbf{.10 \text{ GPM} \times \text{FSF}} & \mathbf{\#N \times \text{SGPM}} & \mathbf{\text{TGPM} \times \%F \times T} & \mathbf{\text{FCN} \times 33} \\ \text{(FAR)} & \text{(TGPM)} & \text{(FCN)} & \text{(FSA)} \end{array}$$

3) *ANSWER:*

190 gallons per minute will be used to combat this incident at 95 GPM, two lines.

240 gallons per minute will be used to combat this incident at 120 GPM, two in-line eductors.

If you are having difficulty calculating the **Total Gallons Per Minute** please **TURN TO PAGE 142 AND START OVER**. If you understand how to calculate the **FCN**, **TURN TO PAGE 147 AND CONTINUE**.

$$\frac{.10 \text{ GPM} \times \text{FSF}}{(\text{FAR})} \times \frac{\#N \times \text{SGPM}}{(\text{TGPM})} \times \frac{\text{TGPM} \times \%F \times T}{(\text{FCN})} = \frac{\text{FCN} \times 33}{(\text{FSA})}$$

CALCULATING THE AMOUNT OF FOAM CONCENTRATE NEEDED

In order to determine the amount of **Foam Concentrate Needed (FCN)** for a flammable liquid spill, prior to extinguishment activities, use the following formula:

$$\text{TGPM} \times \% F \times T$$

Where:

TGPM = Total GPM flow used to extinguish the fire

%F = The percent of the foam concentrate you are applying

T = Time needed to operate (minimum 15 minutes)

Consider the following examples:

Example 1 pre-plumbed: A flammable liquid spill has ignited and is covering a surface area of approximately 1500 square feet. By using the formula **.10 GPM x FSF** the GPM flow needed to extinguish this incident is calculated to be 150 GPM (FAR). At 95 GPM we know we will need two lines and can calculate TGPM by using the formula **#N x SGPM**. 190 GPM will be used to combat this incident. In order to determine the amount of concentrate needed to operate for a minimum of 15 minutes using a foam concentrate of 3%, use the formula **TGPM x %F x T**.

$$\text{TGPM} \times \%F \times T$$

$$190 \text{ GPM} \times 3\% \times 15$$

$$5.7 \times 15$$

86 gallons of foam must be available to operate two 95 GPM lines for 15 minutes.

Example 2 in-line eductor: A flammable liquid spill has ignited and is covering a surface area of approximately 2000 square feet. By using the formula **.10 GPM x FSF** the GPM flow needed to extinguish this incident is calculated to be 200 GPM (FAR). At 120 GPM we know we will need two lines and can calculate TGPM by using the formula **#N x SGPM**. 240 GPM will be used to combat this incident. In order to determine the amount of concentrate needed to operate for a minimum of 15 minutes using a foam concentrate of 3%, use the formula **TGPM x %F x T**.

$$\text{TGPM} \times \%F \times T$$

$$240 \text{ GPM} \times 3\% \times 15$$

$$7.2 \times 15$$

108 gallons of foam must be available to operate two 120 GPM eductors for 15 minutes.

TURN TO PAGE 148

$$\frac{.10 \text{ GPM} \times \text{FSF}}{(\text{FAR})} \quad \frac{\#N \times \text{SGPM}}{(\text{TGPM})} \quad \frac{\text{TGPM} \times \%F \times T}{(\text{FCN})} \quad \frac{\text{FCN} \times 33}{(\text{FSA})}$$

1) Solve

Determine the amount of FCN for an incident that requires the use of 270 GPM (FAR), at 3% foam, for an operation time of 15 minutes, for a pre-plumbed line and an in-line eductor.

$$\begin{aligned} &\text{TGPM} \times \%F \times T \\ &\underline{\hspace{2cm}} \text{ GPM} \times 3\% \times 15 \\ &\underline{\hspace{2cm}} \times \underline{\hspace{2cm}} \\ &\underline{\hspace{2cm}} \text{ gallons of foam must be available to operate at 3\% foam for 15 minutes.} \end{aligned}$$

$$\begin{aligned} &\text{TGPM} \times \%F \times T \\ &\underline{\hspace{2cm}} \text{ GPM} \times 3\% \times 15 \\ &\underline{\hspace{2cm}} \times \underline{\hspace{2cm}} \\ &\underline{\hspace{2cm}} \text{ gallons of foam must be available to operated at 3\% foam for 15 minutes.} \end{aligned}$$

TURN TO PAGE 149

.10 GPM x FSF #N x SGPM TGPM x %F x T FCN x 33
(FAR) (TGPM) (FCN) (FSA)

1) *ANSWER*

128 gallons of foam must be available to operate 285 GPM, @ 3% foam for 15 minutes, at 95 GPM setting.

162 gallons of foam must be available to operate 360 GPM, @ 3% foam for 15 minutes, at 120 GPM setting.

2) Solve

Determine the amount of FCN for an incident that requires the use of 360 GPM (FAR), at 3% foam, for an operation time of 15 minutes, for a pre-plumbed line and an in-line eductor.

TGPM x %F x T
 _____ GPM x 3% x 15
 _____ x _____
 _____ gallons of foam must be available to operate at 3% foam for 15 minutes.

TGPM x %F x T
 _____ GPM x 3% x 15
 _____ x _____
 _____ gallons of foam must be available to operate at 3% foam for 15 minutes.

TURN TO PAGE 150

$$.10 \text{ GPM} \times \text{FSF} \quad \#N \times \text{SGPM} \quad \text{TGPM} \times \%F \times T \quad \text{FCN} \times 33$$

(FAR)
(TGPM)
(FCN)
(FSA)

2) ANSWER

171 gallons of foam must be available to operate 380 GPM, @ 3% foam for 15 minutes, at 95 GPM setting.

162 gallons of foam must be available to operate 360 GPM, @ 3% foam for 15 minutes, at 120 GPM setting.

3) Solve

Determine the amount of FCN for an incident that requires the use of 190 GPM, 3% foam, and an operation time of 15 minutes, for a pre-plumbed line and an in-line eductor.

TGPM x %F x T
 _____ GPM x 3% x 15
 _____ x _____
 _____ gallons of foam must be available to operate at 3% foam for 15 minutes.

TGPM x %F x T
 _____ GPM x 3% x 15
 _____ x _____
 _____ gallons of foam must be available to operate at 3% foam for 15 minutes.

TURN TO PAGE 151

$$\frac{.10 \text{ GPM} \times \text{FSF}}{(\text{FAR})} \quad \frac{\#N \times \text{SGPM}}{(\text{TGPM})} \quad \frac{\text{TGPM} \times \%F \times T}{(\text{FCN})} \quad \frac{\text{FCN} \times 33}{(\text{FSA})}$$

3) *ANSWER:*

86 gallons of foam must be available to operate 190 GPM, @ 3% foam for 15 minutes, at 95 GPM setting.

108 gallons of foam must be available to operate 240 GPM, @ 3% foam for 15 minutes, at 120 GPM setting.

If you are having difficulty calculating the amount of **Foam Concentration Needed** please **TURN TO PAGE 147 AND START OVER**. If you understand how to calculate the **FCN**, **TURN TO PAGE 152 AND CONTINUE**.

$$\frac{.10 \text{ GPM} \times \text{FSF}}{(\text{FAR})} \quad \frac{\#N \times \text{SGPM}}{(\text{TGPM})} \quad \frac{\text{TGPM} \times \%F \times T}{(\text{FCN})} \quad \frac{\text{FCN} \times 33}{(\text{FSA})}$$

Calculating The Amount of Foam Solution Available

In order to determine the total amount of **Foam Solution Available (FSA)**, which is what will provide the GPM flow, take the amount of **Foam Concentration Needed** and multiply it by 33.

Consider the following examples:

Example 1 pre-plumbed: At a flammable liquid spill of approximately 950 square feet, you have determined that before firefighting operations may start you must have 36 gallons of foam concentrate. By using the formula $\text{FCN} \times 33$ the total amount of solution that you will have available to flow will be known.

FCN x 33
 43 x 33
 1,419 gallons of **Foam Solution Available**

Example 2 in-line eductor: At a flammable liquid spill of approximately 1200 square feet, you have determined that before firefighting operations may start you must have 36 gallons of foam concentrate. By using the formula $\text{FCN} \times 33$ the total amount of solution that you will have available to flow will be known.

FCN x 33
 54 x 33
 1,782 gallons of **Foam Solution Available**

The Engineer can now make a determination on the type of water supply that should be obtained.

NOTE: No additional problems for calculating the **Foam Solution Available** are listed in this section due to the simplicity of this equation. Very simply, all you are doing is multiplying the amount of **FCN** times the ratio of water, to give you the total **FSA**.

TURN TO PAGE 153

$$EP = NP + FL + A (\pm) H$$

Calculating Foam Lays- using a pre-plumbed line

Once it is determined that there is enough foam available to operate at a fire scene, the calculation of a foam lay to is very simple. The standard rated flow (SGPM) for a pre-plumbed line is 95 GPM at 100 PSI. The operator must then calculate for FL, A, and H. If there are no appliance or head pressure changes, the maximum operating length from the pump is 1,050 feet. To operate, turn the system on, select the desired percentage of foam, and open the discharge.

Consider the following example:



INLET PRESSURE + FRICTION LOSS + HEAD

$$NP = 100 \text{ PSI}$$

$$FL = 28 \text{ PSI (14 per 100)}$$

$$A = 0 \text{ PSI}$$

$$H = 0 \text{ PSI}$$

$$EP = 128 \text{ PSI}$$

Federal Fire Department Foam Lay Standards:

Use 1 3/4 inch hose at 95 GPM with a 1 1/2" TFT nozzle and Thunderfog attachment for Class B fires.

The Engineer will need to keep track of the foam levels, to provide constant foam.

TURN TO PAGE 154

INLET PRESSURE + FRICTION LOSS + HEAD

Calculating Foam Lays- using a in-line eductor

Once it is determined that there is enough foam available to operate at a fire scene, the calculation of a foam lay to an eductor is very simple. The Angus 450 eductor has a rated flow of 120 GPM at 100 PSI. This calculation comes from the outlet side. There is a 20% pressure loss through this type of eductor. For example, if you pump 100 PSI to the inlet side, you will actually get 80 PSI to the outlet side. In order to provide the correct flow out the nozzle, 150 PSI needs to be delivered to the inlet side of the eductor. The foam nozzle should be no more than 150 feet from the eductor, but can be used in lengths of 50 or 100 feet too. However, the eductor can be placed in line up to 450 feet from the pump when using 1 3/4 inch hose and a 120 GPM eductor. This allows for a total operating length of 600 feet from the pump.

Consider the following example:

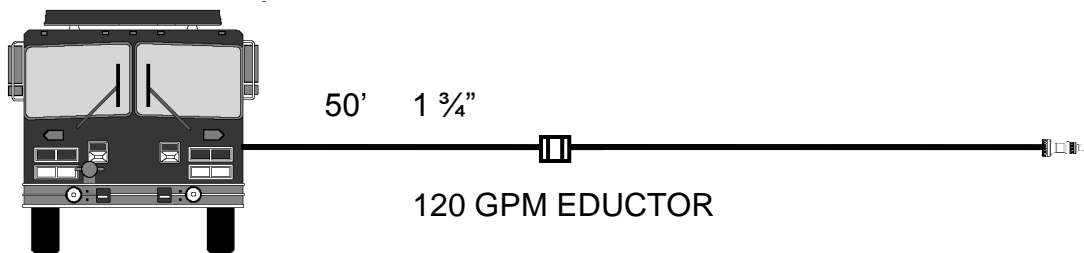

INLET PRESSURE + FRICTION LOSS + HEAD

$$IP = 150 \text{ PSI}$$

$$FL = 11 \text{ PSI}$$

$$H = 0 \text{ PSI}$$

$$EP = 161 \text{ PSI}$$

Federal Fire Department Foam Lay Standards:

Use 1 3/4 inch hose. 200' is the maximum length you can extend past the eductor. Place the eductor within the first 50 feet of hose whenever possible. This allows for the Engineer to keep track of the eductor, and help to provide constant foam.

TURN TO PAGE 155

$$EP = NP + FL + A (\pm) H$$

1) Solve

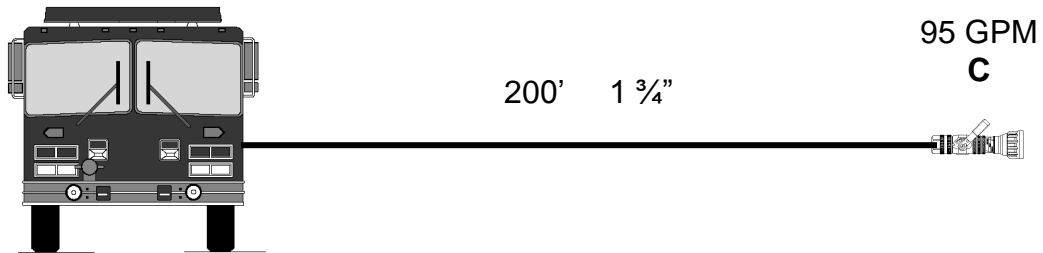

$$EP = NP + FL + A (\pm) H$$

NP = _____

FL = _____

A = _____

H = _____

EP = _____

TURN TO PAGE 156

INLET PRESSURE + FRICTION LOSS + HEAD

1) ANSWER

$$NP = 100 \text{ PSI}$$

$$FL = 21 \text{ PSI}$$

$$A = 0 \text{ PSI}$$

$$H = 0 \text{ PSI}$$

$$EP = 121 \text{ PSI}$$

2) Solve

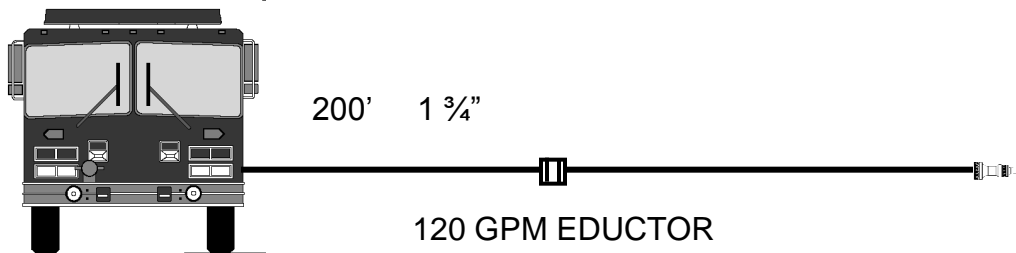

INLET PRESSURE + FRICTION LOSS + HEAD

$$IP = \underline{\hspace{2cm}}$$

$$FL = \underline{\hspace{2cm}}$$

$$H = \underline{\hspace{2cm}}$$

$$EP = \underline{\hspace{2cm}}$$

TURN TO PAGE 157

$$EP = NP + FL + A (\pm) H$$

2) ANSWER

$$IP = 150 \text{ PSI}$$

$$FL = 45 \text{ PSI}$$

$$H = 0 \text{ PSI}$$

$$EP = 195 \text{ PSI}$$

3) Solve

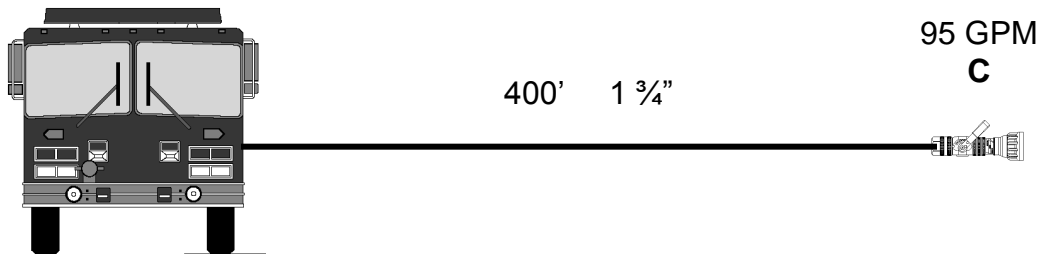

$$EP = NP + FL + A (\pm) H$$

$$NP = \underline{\hspace{2cm}}$$

$$FL = \underline{\hspace{2cm}}$$

$$A = \underline{\hspace{2cm}}$$

$$H = \underline{\hspace{2cm}}$$

$$EP = \underline{\hspace{2cm}}$$

TURN TO PAGE 158

INLET PRESSURE + FRICTION LOSS + HEAD

3) ANSWER

$$IP = 100 \text{ PSI}$$

$$FL = 56 \text{ PSI}$$

$$A = 0 \text{ PSI}$$

$$H = 0 \text{ PSI}$$

$$EP = 156 \text{ PSI}$$

4) Solve

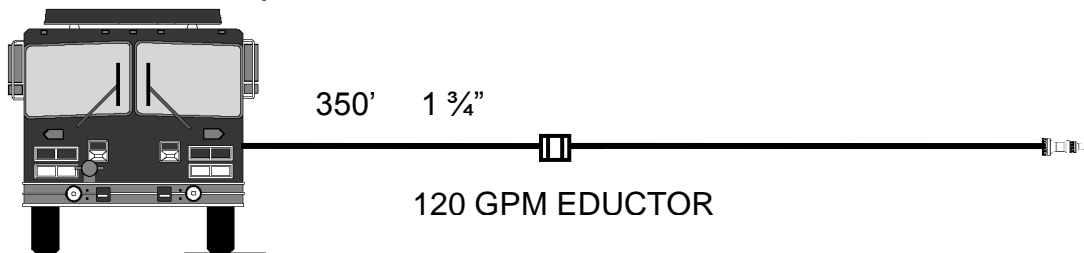

INLET PRESSURE + FRICTION LOSS + HEAD

$$IP = \underline{\hspace{2cm}}$$

$$FL = \underline{\hspace{2cm}}$$

$$H = \underline{\hspace{2cm}}$$

$$EP = \underline{\hspace{2cm}}$$

TURN TO PAGE 159

INLET PRESSURE + FRICTION LOSS + HEAD

4) ANSWER:

IP = 150 PSI

FL = 78 PSI

H = 0 PSI

EP = 228 PSI

TURN TO PAGE 160

CHAPTER V SUMMARY

1) In order to determine the **Foam Application Rate (FAR)**, which tells you GPM flow needed to extinguish a certain size of flammable liquid spill, use the following formula:

.10 GPM x FSF

.10 GPM standard for hydrocarbons= Gallons per minute of foam solution needed per 1 square foot of fire, most common. FSF = fire per square foot.

.20 GPM X FSF

.20 GPM standard for polar solvents= Gallons per minute of foam solution needed per 1 square foot of fire. FSF = fire per square foot.

2) In order to determine the amount of **Total Gallons Per Minute (TGPM)** for the flow rate, use the following formula:

#N x SGPM

#N = Number of nozzles or in-line eductors to extinguish this fire. *Calculated by dividing the Foam Application rate by the Standard GPM setting and round up to the next whole number.*

SGPM = The standard setting of the nozzle you are using, either 95 GPM pre-plumbed line or 120 GPM in-line eductor.

3) In order to determine the **Foam Concentration Needed (FCN)**, which tells you how much foam concentration you will need to have available to operate over a set period of time, use the following formula:

TGPM x % F x T

TGPM = Total GPM flow used to extinguish the fire

%F = Percent of foam being used (In most cases this will be 3%.)

T = Time needed to operate (This will be a minimum of fifteen minutes, but could be longer.)

4) In order to determine the **Foam Solution Available (FSA)**, which tells you how much solution you will have available once you have determined the amount of foam needed, use the following formula:

FCN x 33

FCN = Foam Concentration Needed

33 = A constant (This represents the amount of water needed to mix with the FCN.)

5) Once it is determined that there is enough foam available to operate at a fire scene, the calculation of a foam lay to an eductor is very simple. Use the following formulas:

EP = NP + FL + A (±) H for pre-plumbed lines

EP = Engine Pressure

NP = Nozzle Pressure

FL = Friction loss in the hose

A = Appliance

H = Head pressure

IP x FL x H for in-line eductors

IP = The Inlet Pressure of the eductor, normally 150 PSI

FL = Friction loss in the hose up to the eductor

H = Head pressure

TURN TO PAGE 162

CHAPTER VI

DETERMINING ENGINE PRESSURE USING THE FIELD HYDRAULICS

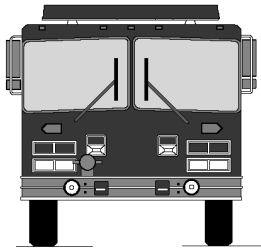

REFERENCE SHEET
(FHRS)

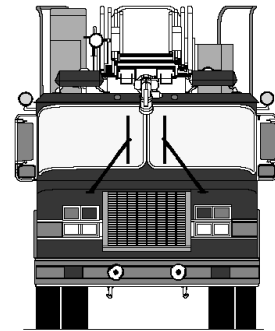

$$\mathbf{EP = NP + FL + A (\pm) H}$$

INTRODUCTION

Although there are several ways to compute Engine Pressure (EP), the Federal Fire Department has adopted one method because of its simplicity for field use:

$$\mathbf{EP = NP + FL + A (\pm) H}$$

To assist you, we have included as a quick reference, a “Field Hydraulics Reference Sheet” (FHRS) in the back of this manual. You might want to copy this sheet and shrink it to a size that you can keep with you while you’re on duty to help you with your calculations. The problems in this chapter are designed to familiarize you with the Field Hydraulics Reference Sheet’s use.

TURN TO PAGE 164

$$EP = NP + FL + A (\pm) H$$

HOW TO USE THE FIELD HYDRAULICS REFERENCE SHEET (FHRS)

Using the **GPM & FRICTION LOSS TABLES** on the FHRS, determine how much water is flowing from a 1 1/8 inch, hand held tip on a 2 1/2 inch hose.

What is the Friction Loss?

Let's work this together:

Find 1 1/8 inch tip under the GPM table. Less than 1 1/8 inch tip you see that there are two figures (80, 210).

These figures are the gallons per minute (GPM). Now look to the left of these figures, at the Nozzle Pressure Column. You should find 50 PSI, and 80 PSI.

Remember from Chapter II that **hand held tips are 50 PSI (NP)**. Locate 50 PSI in the first row. Follow that row towards the right to the 1 1/8 inch column. Here we find the number 265. This is your GPM.

Now that we know the GPM and the size of the hose, we need to find the Friction Loss (FL). To do this, we move down to the **Friction Loss Table**. The top row across is GPM in 50 GPM increments. The first column down is the size of the hose. To the right of the Hose Column under the GPM row is the friction loss (FL) for that particular size hose and its GPM.

Our original problem was to find the GPM and the Friction Loss for a 1 1/8 inch tip on a hand held 2 1/2 inch line. We already know from the **GPM Table** that the GPM is 265.

Now, in the GPM row, in the Friction Loss Table, we look for the number 265. We see that the number is not there. However, the numbers 250 and 300 are there. Because 265 is closer to 250 than 300, use 250 GPM. (*Remember, we are using quick field calculations only.*). The formula for calculating exact figures is **FL = CQ²L** and was discussed in Chapter II.

CONTINUE ON PAGE 165

$$EP = NP + FL + A (\pm) H$$

We know from our example that the hose being used is a 2 ½ inch line. Find 2 ½ inch in the left hand column. Follow that row over to the 250 GPM columns, and you will find the number 13. That is your friction loss for 2 ½ inch hose at 250 GPM.

NOTE: The friction loss figures taken from the “**FRICITION LOSS TABLE**” are for 100 foot increments of hose.

If you have 200 feet of hose, the FL would be:	2 x 13
With 300 feet of hose, the FL would be:	3 x 13, etc.

REMEMBER: To use these charts, you need to know:

1) The use, size, and number of lines of hose

AND

2) Either the tip size, nozzle type, or the GPM flowing

NOW WHY DON'T YOU TRY A COUPLE ON YOUR OWN?

TURN TO PAGE 166

$$EP = NP + FL + A (\pm) H$$

1) What is the Friction Loss on a 1 inch tip on a 2 ½ inch handline? What is the flow?

Write in the answer:

1" Tip

_____ Friction Loss

_____ GPM's

1) What is the Friction Loss on a 1 ½ inch combination nozzle on 1 ¾ inch hose? What is the flow?

Write in the answer:

1 ½" Combination

_____ Friction Loss

_____ GPM's

TURN TO PAGE 167 FOR ANSWERS

$$EP = NP + FL + A (\pm) H$$

1) ANSWER

1" Tip

8 PSI Friction Loss

210 GPM's

2) ANSWER

1 1/2" Combination

35 PSI Friction Loss

150 GPM's

If you understand how to use the Friction Loss and GPM Tables, **TURN TO PAGE 168.**
If not, **RETURN TO PAGE 164 AND BEGIN AGAIN.**

$$EP = NP + FL + A (\pm) H$$

1) Solve

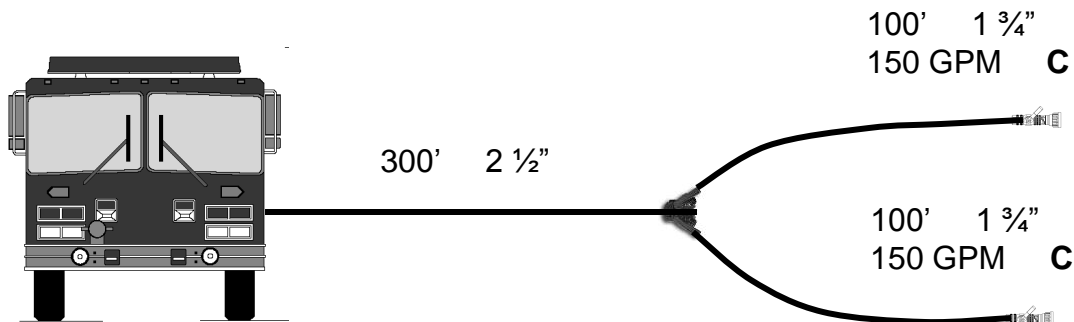

Let's solve this one together. It is easiest to begin at the end of the hoselay and work your way from the nozzle back to the engine.

The nozzle pressure is 100 PSI because they are combination nozzles. Look at the **Field Hydraulic Reference Sheet** and in the GPM row find 150 GPM. Now look down the Hose Size Column and find 1 3/4 inch hose. Next, look from the left to right and find the number 35. That is the friction loss for 1 3/4 inch hose only. You add only 35 PSI for both 1 3/4 inch hoses (bundles) because it would be the same as running each hose off two separate discharges on the engine.

The appliance, a gated wye, has 10 PSI FL. To figure the friction loss on the 2 1/2 inch supply hose we must know the amount of GPM flow from the two nozzles. We know that one bundle flows 150 GPM, so two bundles would be twice that amount, 300 GPM. Look at the **Field Hydraulics Reference Sheet**, and in the GPM Row find 300 GPM. Now look down the Size Hose Column and find 2 1/2 inch hose. Next, look from left to right to where the GPM Row and the Hose Size Column meet. This number is 18. This number is the FL for 100 feet of 2 1/2 inch hose. Since we have 300 feet of 2 1/2 inch hose, the FL would be 3 x 18 PSI = 54 PSI FL.

Therefore, the total Engine Pressure is:

<u>Combination</u> Nozzle	NP	100 PSI
1 3/4" bundles	FL	35 PSI
2 1/2" supply	FL	54 PSI
Wye	A	10 PSI
<u>Head</u>	<u>±H</u>	<u>+0 PSI</u>
ENGINE PRESSURE	EP	=199 PSI

TURN TO PAGE 169

$$EP = NP + FL + A (\pm) H$$

Solve

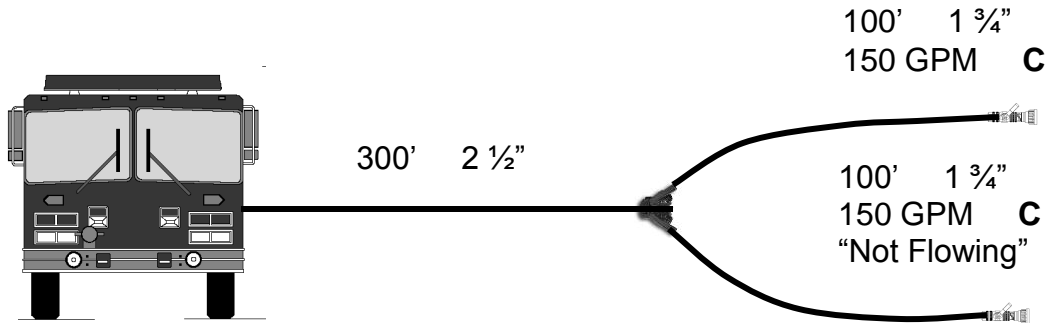

Write in answers

NP = _____

FL = _____

A = _____

$\pm H$ = _____

EP = _____

TURN TO PAGE 170

$$EP = NP + FL + A (\pm) H$$

ANSWER:

NP = 100 PSI

FL = 50 PSI (1 ¾ inch hose 35 PSI FL)

(2 ½ inch hose 15 PSI FL)

A = 10 PSI

±H = 0 PSI

EP = 160 PSI

If you solved this problem correctly, OUTSTANDING!

If, however, you had some difficulties with this exercise, please follow along:

This problem is similar to the one on the preceding pages. However, instead of pumping both bundles (two 1 ¾ inch lines at 300 GPM), we are now pumping one bundle, or one 1 ¾ inch line at 150 GPM.

Nozzle Pressure is still **100 PSI NP**

FL for the 1 ¾ inch hose is **35 PSI**. Remember whether we are pumping one bundle or two off the same supply line, we figure the FL for 150 GPM only.

The friction loss for the 2 ½ inch supply line is figured at 150 GPM. This calculates to 5 PSI per 100 feet. Since we have 300 feet of 2 ½ inch hose, the FL would be 3 x 5 = **15 PSI**. We need to add the FL for both hoses, bundles, and supply lines, therefore, **Total FL** = (35 PSI + 15 PSI = **50 PSI FL**).

The Appliance Friction Loss for a wye is **10 PSI**.

Although elevation (±H) is not a factor in this problem, you should develop the habit of considering **ALL FACTORS** of the Engine Pressure formula.

TURN TO PAGE 171

$$EP = NP + FL + A (\pm) H$$

Get some scratch paper and have your Field Hydraulics Reference Sheet in front of you. Now you can begin solving some hydraulics problems.

Solve

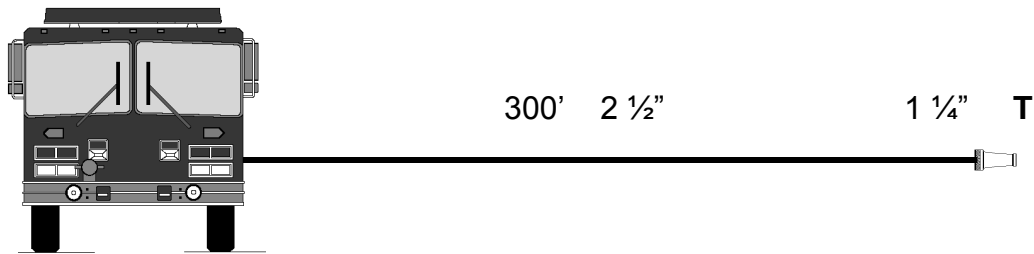

Write in answers

NP = _____

FL = _____

A = _____

$\pm H$ = _____

EP = _____

TURN TO PAGE 172

$$\mathbf{EP = NP + FL + A (\pm) H}$$

ANSWERS

$$\begin{aligned} \text{NP} &= 50 \\ \text{FL} &= 63 \\ \text{A} &= 0 \\ \pm\text{H} &= 0 \\ \mathbf{EP} &= \mathbf{113} \end{aligned}$$

Because it is a hand held tip, the Nozzle Pressure is **50 PSI NP**. Looking at the GPM Chart of the Reference Sheet, you see that a 1 ¼ inch tip discharges 325 GPM at 50 PSI.

In the Friction Loss Table we find GPM columns for 300 and 350 GPM, but nothing for 325 GPM. We also see that the FL for 300 GPM is 18 PSI and 25 PSI for 350 GPM. For field calculations we could interpolate and round off to 21 PSI FL, which would be close for 325 GPM.

Since 300 feet of 2 ½ inch hose is three 100 foot sections, 3 x 21 PSI = **63 PSI FL**. There are no Appliances or Head.

So the **Engine Pressure (EP)** is **113 PSI**.

TURN TO PAGE 173

$$EP = NP + FL + A (\pm) H$$

At the back of this book, along with the Field Hydraulics Reference Sheet, you will find a Wildland Hydraulics and Foam Reference Sheet. This chart is used in the same manner as the Field Hydraulics Reference Sheet. It also has the tip sizes along the top row, Nozzle Pressure down the left hand column, and GPM running left to right.

To figure GPM using this chart, you need to know the Tip Size and Nozzle Pressure.

Example:

A 1 inch wildland combination nozzle at 100 PSI Nozzle Pressure flows between 5 and 40 GPM, depending on the nozzle setting. Use the established standard setting of 20 GPM.

Now that you know the GPM, you could use the Friction Loss formula CQ^2L to find the Friction Loss, as long as you also know your hose size and length of lay.

TURN TO PAGE 174

$$EP = NP + FL + A (\pm) H$$

Solve

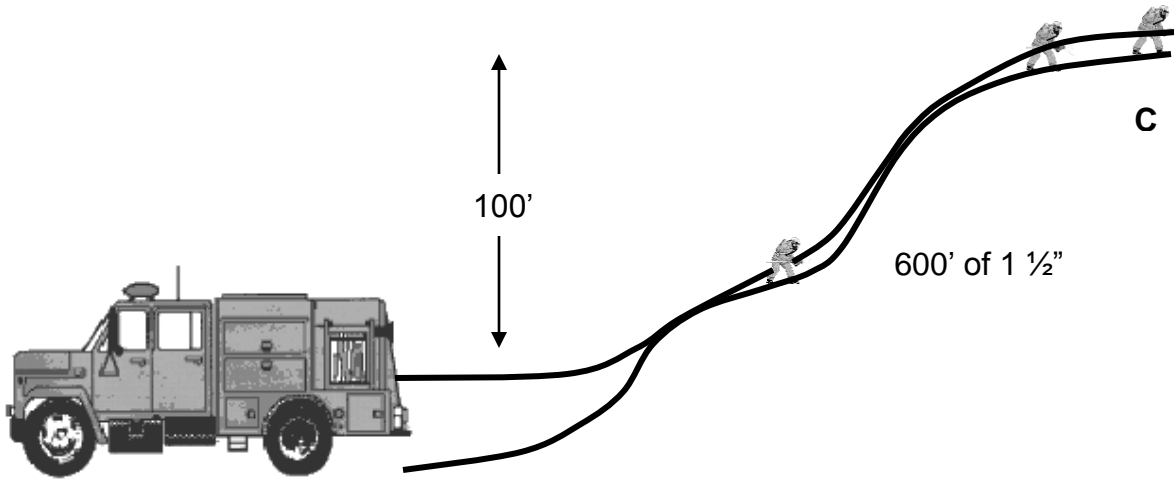

Write in answers

NP = _____

FL = _____

A = _____

$\pm H$ = _____

EP = _____

TURN TO PAGE 175

$$\mathbf{EP = NP + FL + A (\pm) H}$$

If you calculated 179 PSI, CONGRATULATIONS!

TURN TO PAGE 177 AND PROCEED.

If you did not get 179 PSI for your answer, **TURN TO PAGE 176** for the correct answer and explanation.

$$\mathbf{EP = NP + FL + A (\pm) H}$$

ANSWERS

$$\begin{aligned} \text{NP} &= 100 \text{ PSI} \\ \text{FL} &= 36 \text{ PSI} \\ \text{A} &= 0 \text{ PSI} \\ \pm\text{H} &= +43 \text{ PSI} \\ \mathbf{EP} &= \mathbf{179 \text{ PSI}} \end{aligned}$$

Nozzle Pressure (NP) is 100 PSI because it is a combination nozzle.

To figure the Friction loss, we need to refer to the Wildland Hydraulics Reference Sheet. We find that a 1 inch combination nozzle at 100 PSI NP flows between 5 and 40 GPM with a standard of 20 GPM. Using the formula and coefficients learned in Chapter II, we are now able to figure the Friction Loss (FL) in the hoselay.

$$\text{FL} = \text{CQ}^2\text{L}$$

$$\text{FL} = 24 \times (20/100)^2 \times (600/100)$$

$$\text{FL} = 24 \times (.2)^2 \times 6$$

$$\text{FL} = 24 \times 0.04 \times 6$$

$$\mathbf{FL = 6 \text{ PSI}}$$

There are no Appliances, so (**A**) = **0**. Because the nozzle is above the pump, you must add Head. We also learned in Chapter II that 100 feet of elevation (**H**) equals **43 PSI**; therefore **Engine Pressure equals 179 PSI**.

TURN TO PAGE 177

$$EP = NP + FL + A (\pm) H$$

Solve

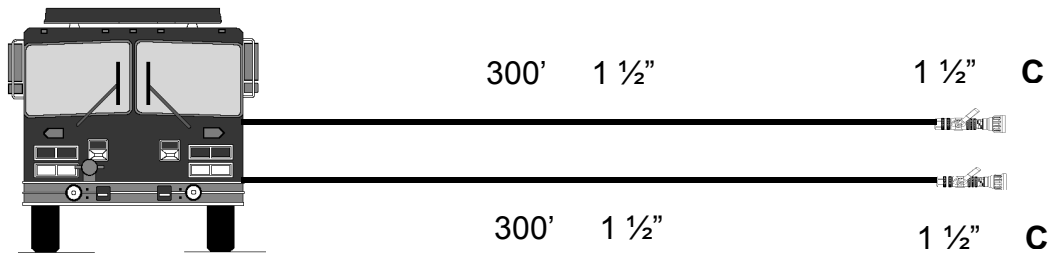

Write in answers

NP = _____

FL = _____

A = _____

$\pm H$ = _____

EP = _____

TURN TO PAGE 178

$$EP = NP + FL + A (\pm) H$$

ANSWERS

NP = 100 PSI
FL = 114 PSI
A = 0 PSI
 $\pm H = 0$ PSI
EP = 214 PSI

Nozzle Pressure (NP) is 100 PSI because it is a combination nozzle. A 1 ½ inch combination nozzle on a 1 ½ inch hose has 38 PSI FL per 100 feet of hose. Three 100 foot sections at 38 PSI per hundred is 114 PSI total FL. There are no Apliance and no Head so the **EP is 214 PSI.**

QUESTION: Why don't you add FL in for both hose lines?

ANSWER: You would agree that the EP is 214 for one line.

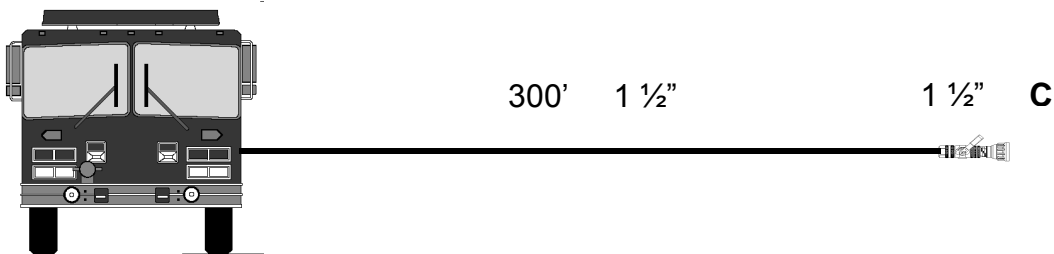

FOLLOW ALONG ON PAGE 179

$$EP = NP + FL + A (\pm) H$$

Per the Chart, you are flowing 125 GPMs with one line.

Let's add the other line and see what is happening.

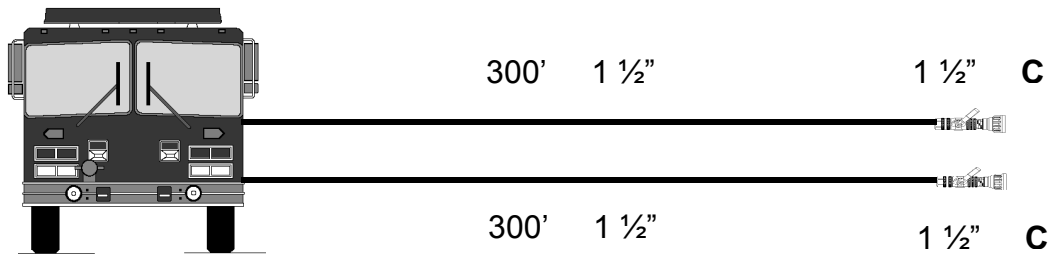

When you add the second line, which is identical to the first line, the EP remains the same. What is happening is that the pump is working harder because you are flowing more water. **All you are doing is increasing the engine speed of the pump to deliver this greater quantity of water, so you only figure EP for the one line.**

TURN TO PAGE 180

$$EP = NP + FL + A (\pm) H$$

Solve

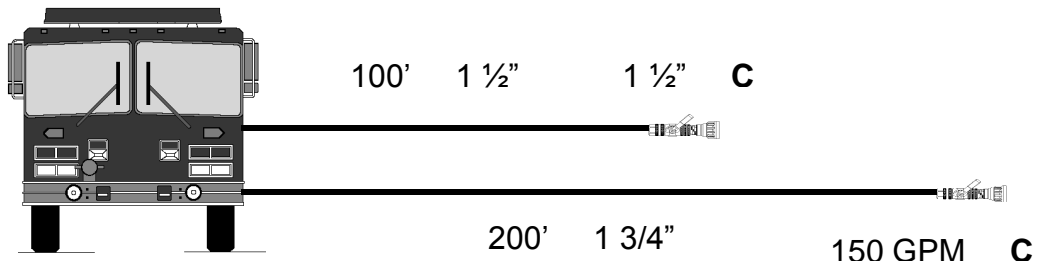

Write in answers

NP = _____

FL = _____

A = _____

$\pm H$ = _____

EP = _____

TURN TO PAGE 181

$$\mathbf{EP = NP + FL + A (\pm) H}$$

ANSWERS

$$\text{NP} = 100 \text{ PSI}$$

$$\text{FL} = 70 \text{ PSI}$$

$$\text{A} = 0 \text{ PSI}$$

$$\text{H} = 0 \text{ PSI}$$

$$\mathbf{EP = 170 \text{ PSI}}$$

In figuring two separate lines that are not identical, for the correct EP, figure the line that requires the most Engine Pressure. On the line, which requires less EP, the only thing you can do to prevent excessive Nozzle Pressure is to gate down the discharge while the nozzle is flowing.

TURN TO PAGE 182

$$\mathbf{EP = NP + FL + A (\pm) H}$$

If you are still with us, CONGRATULATE YOURSELF!

If, however, you feel unsure about anything we have covered up to this point, go back to that particular section and review the material. You may want to try working a few problems again.

After a break, sit down with your Field Hydraulics Reference Sheet and writing materials. Now you can begin the final chapter.

TURN TO PAGE 183

$$EP = NP + FL + A (\pm) H$$

Chapter VII

SOLVING HYDRAULICS PROBLEMS

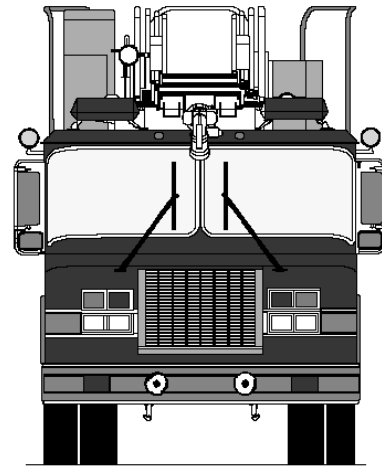
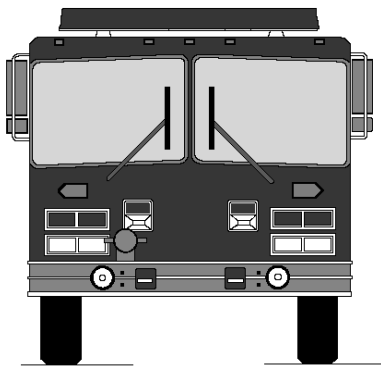

$$EP = NP + FL + A (\pm) H$$

SOLVING HYDRAULICS PROBLEMS

Your job as an Engineer is an important one. You must be prepared to solve hydraulics problems on the fireground quickly. The fireground does not give you the luxury of time when solving hydraulics problems. To stay proficient, you must drill yourself on a routine basis and have your FL card with you at all times.

On the following pages there are 20 problems to solve. Your goal is to be able to solve these problems in 30 minutes and be within 10 PSI of the required Engine Pressure on all 20 problems. The answers for the problems show the actual calculations. If you do not meet this goal, you should continue to drill with hydraulics until you can. It is important to maintain this proficiency in order to be able to provide safe and effective fire streams.

GOOD LUCK!

TURN TO PAGE 185

$$EP = NP + FL + A (\pm) H$$

1) Solve

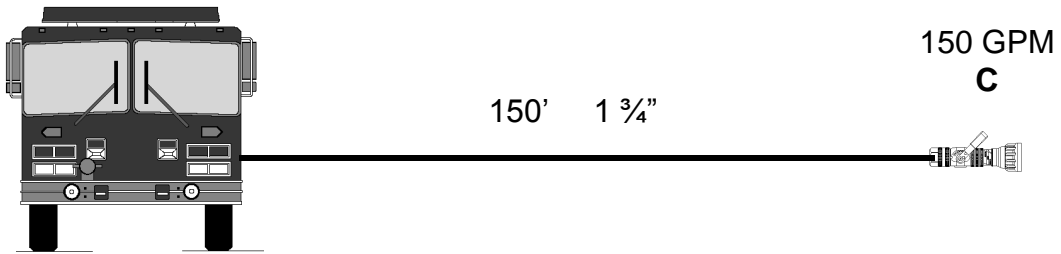

Write in answers

NP = _____

FL = _____

A = _____

$\pm H$ = _____

EP = _____

TURN TO PAGE 186

$$\mathbf{EP = NP + FL + A (\pm) H}$$

1) *ANSWERS*

NP = 100 PSI

FL = 52.5 PSI

A = 0 PSI

H = 0 PSI

EP = 152.5 PSI

TURN TO PAGE 187

$$EP = NP + FL + A (\pm) H$$

2) Solve

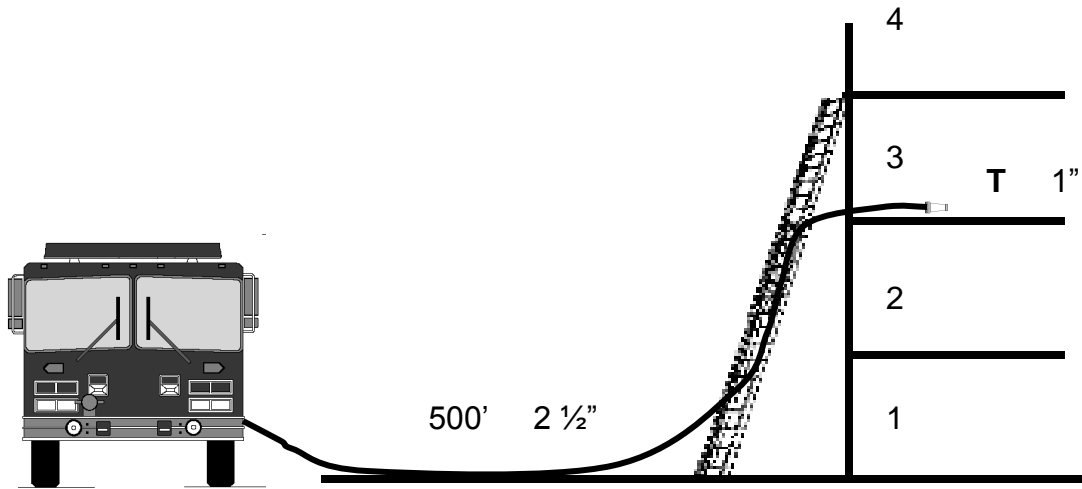

Write in answers

NP = _____

FL = _____

A = _____

$\pm H$ = _____

EP = _____

TURN TO PAGE 188

$$EP = NP + FL + A (\pm) H$$

2) ANSWERS

$$NP = 50 \text{ PSI}$$

$$FL = 44 \text{ PSI}$$

$$A = 0 \text{ PSI}$$

$$H = +10 \text{ PSI}$$

$$EP = \underline{\mathbf{104 \text{ PSI}}}$$

TURN TO PAGE 189

$$EP = NP + FL + A (\pm) H$$

3) Solve

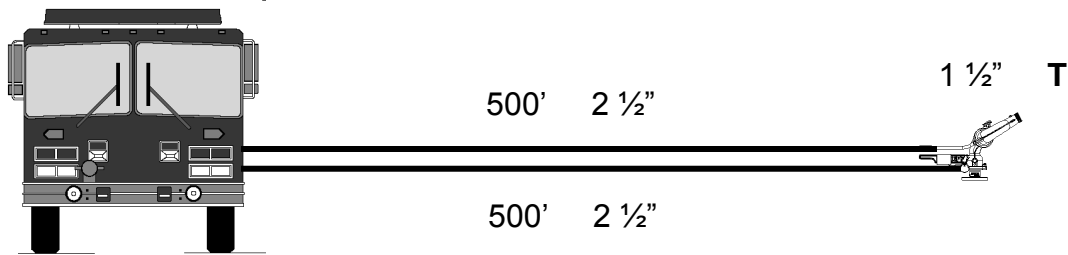

Write in answers

NP = _____

FL = _____

A = _____

$\pm H$ = _____

EP = _____

TURN TO PAGE 190

$$\mathbf{EP = NP + FL + A (\pm) H}$$

3) *ANSWERS*

NP = 80 PSI

FL = 90 PSI

A = 15 PSI

H = 0 PSI

EP = 185 PSI

TURN TO PAGE 191

$$EP = NP + FL + A (\pm) H$$

4) Solve

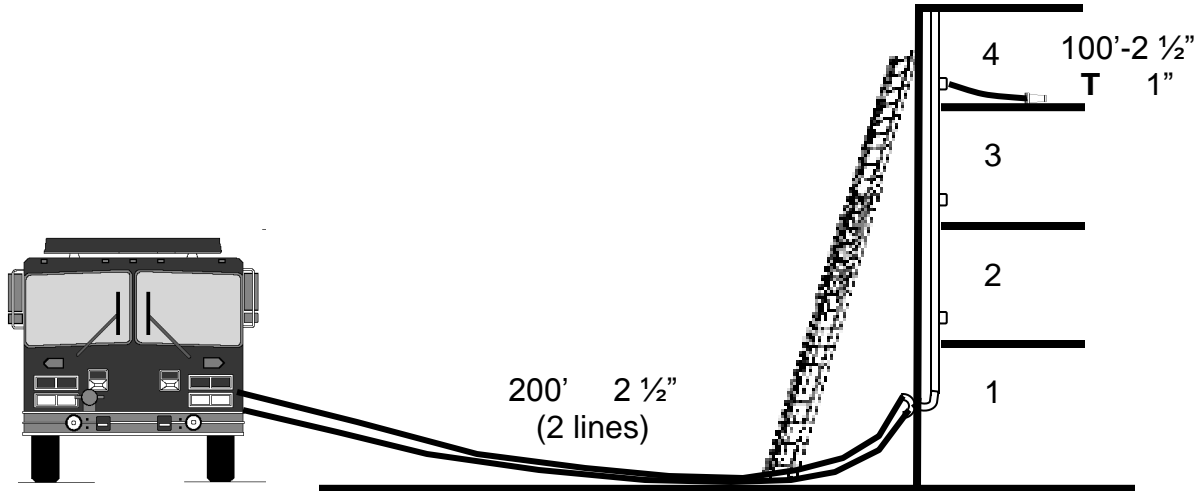

Write in answers

NP = _____

FL = _____

A = _____

±H = _____

EP = _____

TURN TO PAGE 192

$$\mathbf{EP = NP + FL + A (\pm) H}$$

4) *ANSWERS*

NP = 50 PSI

FL = 13 PSI

(One 2 ½ inch hose 9 PSI FL)

(Two 2 ½ inch hose 4 PSI FL)

A = 25 PSI

H = +15 PSI

EP = 103 PSI

TURN TO PAGE 193

$$EP = NP + FL + A (\pm) H$$

5) Solve

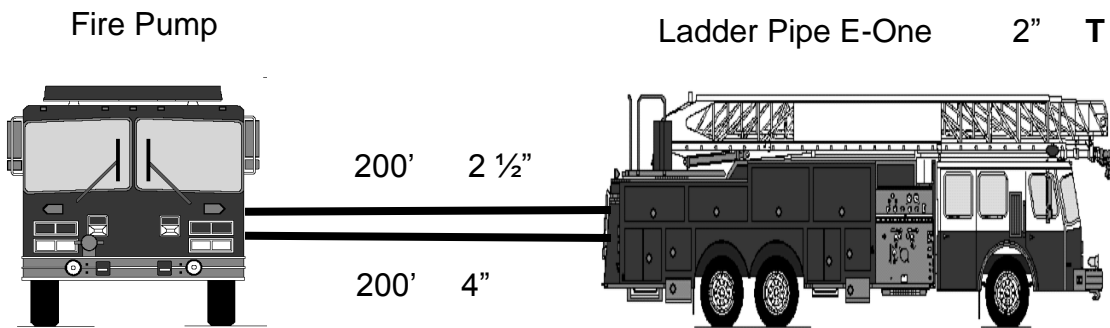

Write in answers

NP = _____

FL = _____

A = _____

$\pm H$ = _____

EP = _____

TURN TO PAGE 194

$$\mathbf{EP = NP + FL + A (\pm) H}$$

5) *ANSWERS*

NP = 80 PSI

FL = 28 PSI

A = 90 PSI

H = 0 PSI

EP = 198 PSI

Note: When using two 4 inch lines, divide GPM in half and figure single line Friction Loss.

TURN TO PAGE 195

$$EP = NP + FL + A (\pm) H$$

6) Solve

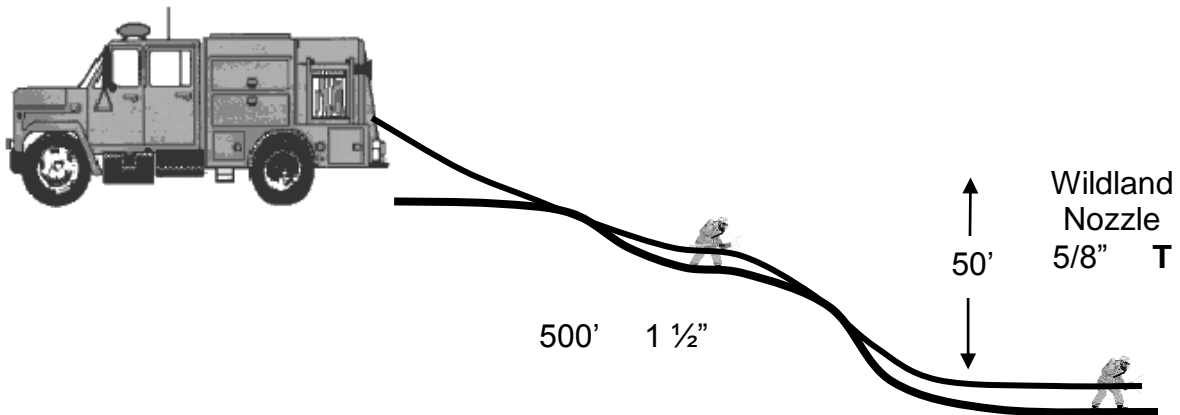

Write in answers

NP = _____

FL = _____

A = _____

$\pm H$ = _____

EP = _____

TURN TO PAGE 196

$$\mathbf{EP = NP + FL + A (\pm) H}$$

6) *ANSWERS*

NP = 100 PSI

FL = 75 PSI

A = 0 PSI

H = -22 PSI

EP = 153 PSI

TURN TO PAGE 197

$$EP = NP + FL + A (\pm) H$$

7) Solve

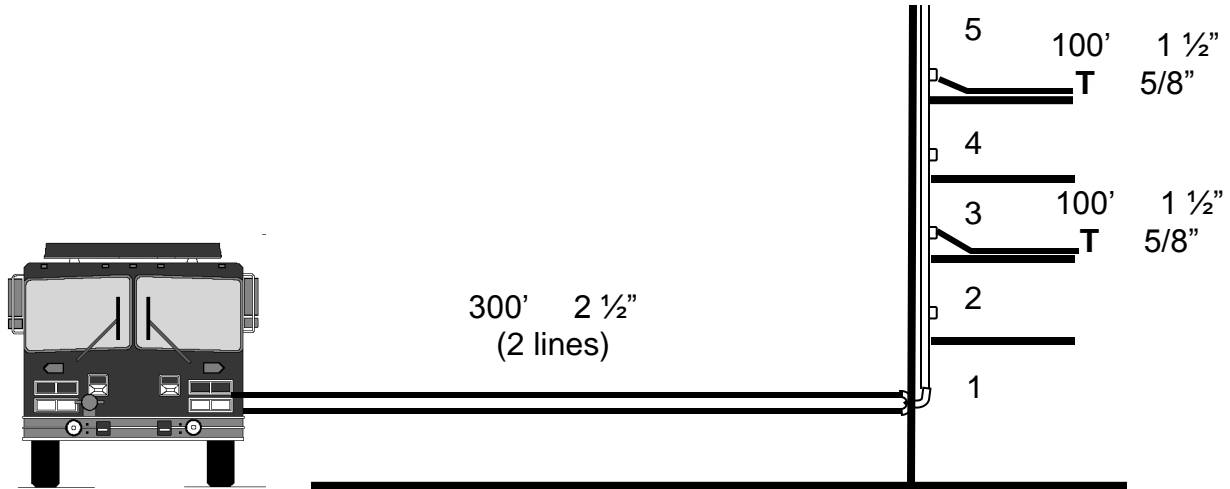

Write in answers

NP = _____

FL = _____

A = _____

±H = _____

EP = _____

TURN TO PAGE 198

$$\mathbf{EP = NP + FL + A (\pm) H}$$

7) *ANSWERS*

NP = 50 PSI

FL = 19 PSI

(1 ½ inch hose 15 PSI)

(2 ½ inch hose 4 PSI)

A = 25 PSI

H = +20 PSI

EP = 114 PSI

TURN TO PAGE 199

INLET PRESSURE + FRICTION LOSS + HEAD

8) Solve

A flammable liquid spill has ignited and is covering a surface area of approximately 1500 square feet.

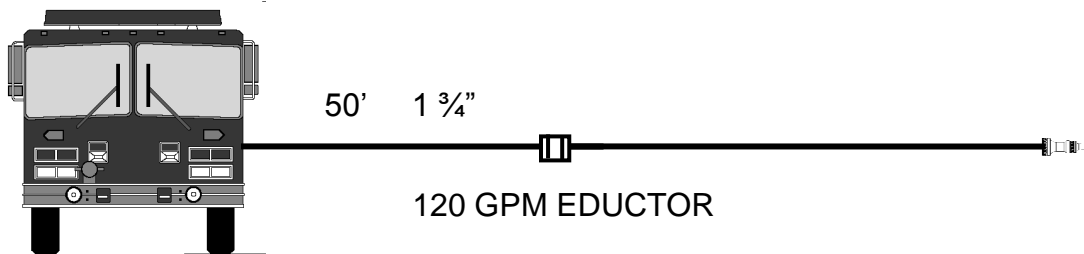

Write in answers

IP = _____

FAR = _____

FL = _____

TGPM = _____

±H = _____

FCN = _____

EP = _____

FSA = _____

TURN TO PAGE 200

INLET PRESSURE + FRICTION LOSS + HEAD

8) *ANSWERS*

IP = 150 PSI

FL = 11 PSI

H = 0 PSI

EP = 161 PSI

FAR = 150

TGPM = 240

FCN = 108

FSA = 3,564

TURN TO PAGE 201

$$EP = NP + FL + A (\pm) H$$

9) Solve

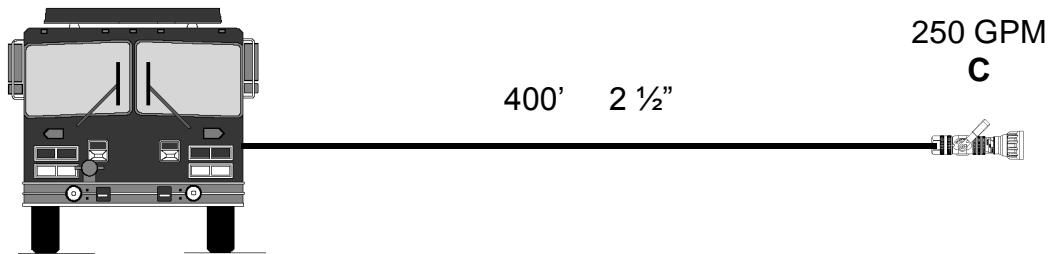

Write in answers

NP = _____

FL = _____

A = _____

$\pm H$ = _____

EP = _____

TURN TO PAGE 202

$$\mathbf{EP = NP + FL + A (\pm) H}$$

9) *ANSWERS*

NP = 100 PSI

FL = 52 PSI

A = 0 PSI

H = 0 PSI

EP = 152 PSI

TURN TO PAGE 203

$$EP = NP + FL + A (\pm) H$$

10) Solve

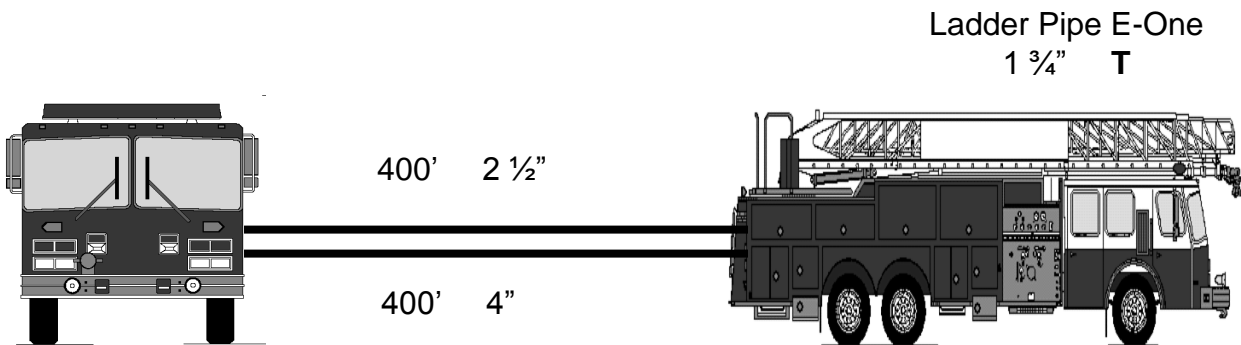

Write in answers

NP = _____

FL = _____

A = _____

$\pm H$ = _____

EP = _____

TURN TO PAGE 204

$$\mathbf{EP = NP + FL + A (\pm) H}$$

10)ANSWERS

NP = 80 PSI

FL = 32 PSI

A = 90 PSI

H = 0 PSI

EP = 202 PSI (pump 200 PSI due to hose safety pressure)

TURN TO PAGE 205

$$EP = NP + FL + A (\pm) H$$

11) Solve

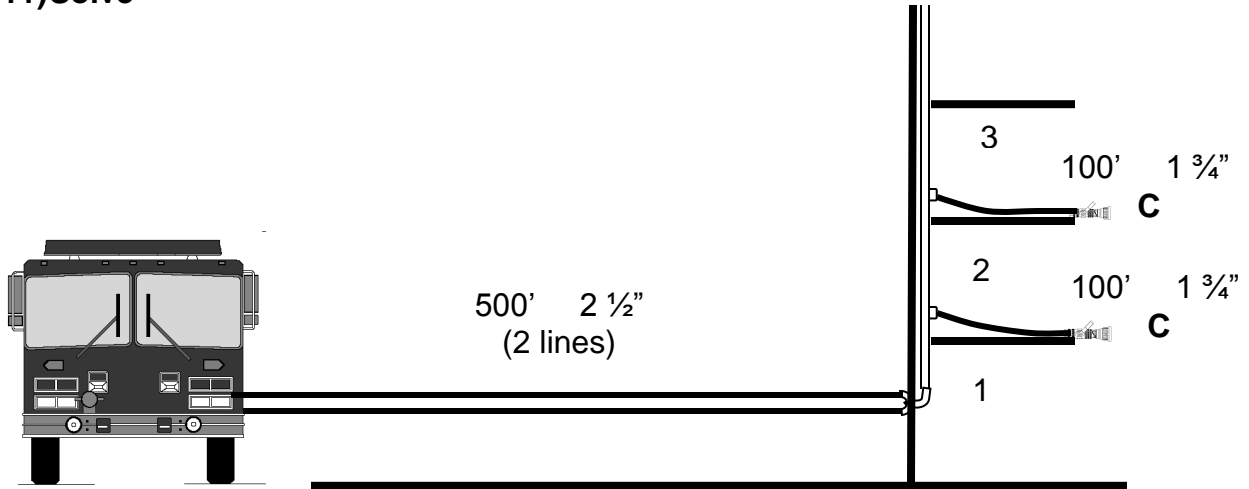

Write in answers

NP = _____

FL = _____

A = _____

$\pm H$ = _____

EP = _____

TURN TO PAGE 206

$$\mathbf{EP = NP + FL + A (\pm) H}$$

11)ANSWERS:

NP = 100 PSI

FL = 58 PSI

(1 $\frac{3}{4}$ inch hose 35 PSI FL)

(2 $\frac{1}{2}$ inch hose 23 PSI FL)

A = 25 PSI

H = 10 PSI

EP = 193 PSI

TURN TO PAGE 207

$$EP = NP + FL + A (\pm) H$$

12) Solve

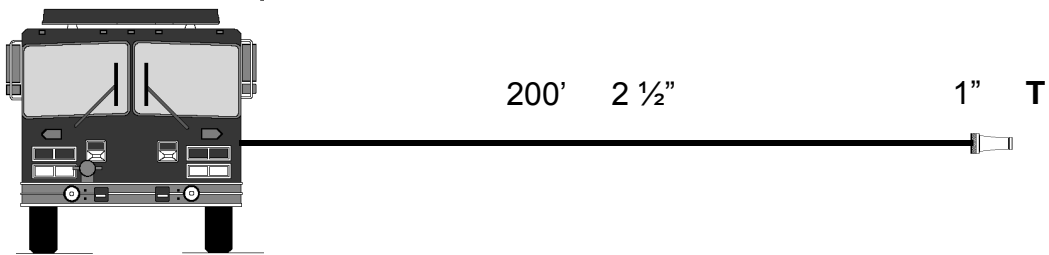

Write in answers

NP = _____

FL = _____

A = _____

$\pm H$ = _____

EP = _____

TURN TO PAGE 208

$$\mathbf{EP = NP + FL + A (\pm) H}$$

12)ANSWERS

NP = 50 PSI

FL = 18 PSI

A = 0 PSI

H = 0 PSI

EP = 68 PSI

TURN TO PAGE 209

$$EP = NP + FL + A (\pm) H$$

13) Solve

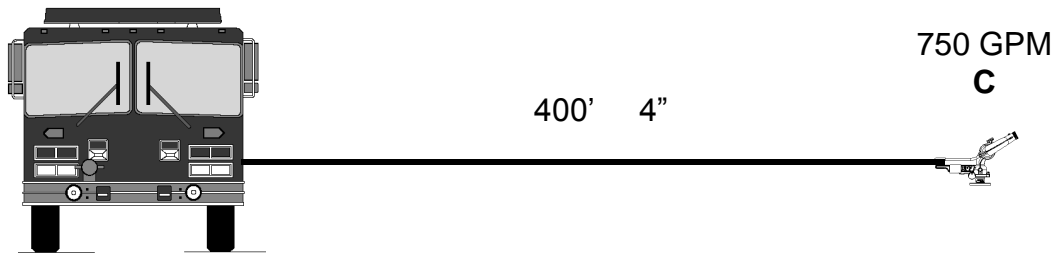

Write in answers

NP = _____

FL = _____

A = _____

$\pm H$ = _____

EP = _____

TURN TO PAGE 210

$$\mathbf{EP = NP + FL + A (\pm) H}$$

13)ANSWERS

NP = 100 PSI

FL = 45 PSI

A = 15 PSI

H = 0 PSI

EP = 160 PSI

TURN TO PAGE 211

$$EP = NP + FL + A (\pm) H$$

14) Solve

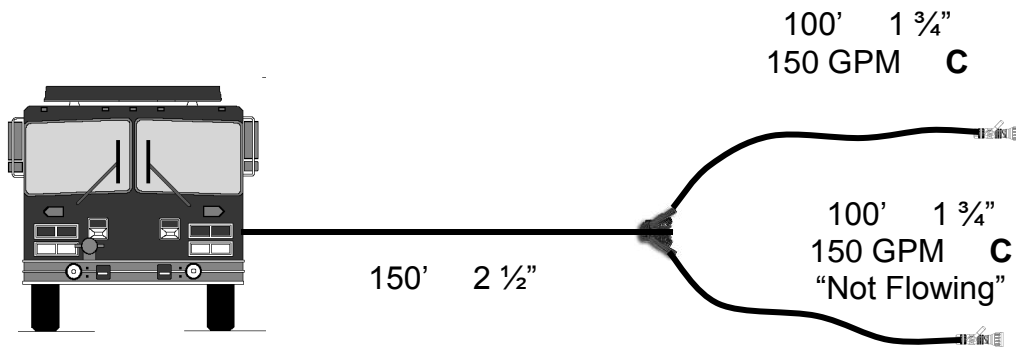

Write in answers

NP = _____

FL = _____

A = _____

$\pm H$ = _____

EP = _____

TURN TO PAGE 212

$$EP = NP + FL + A (\pm) H$$

14) ANSWERS

NP = 100 PSI

FL = 42 PSI

(1 ¾ inch hose 35 PSI FL)

(2 ½ inch hose 7 PSI FL)

A = 10 PSI

H = 0 PSI

EP = 152 PSI

TURN TO PAGE 213

$$EP = NP + FL + A (\pm) H$$

15) Solve

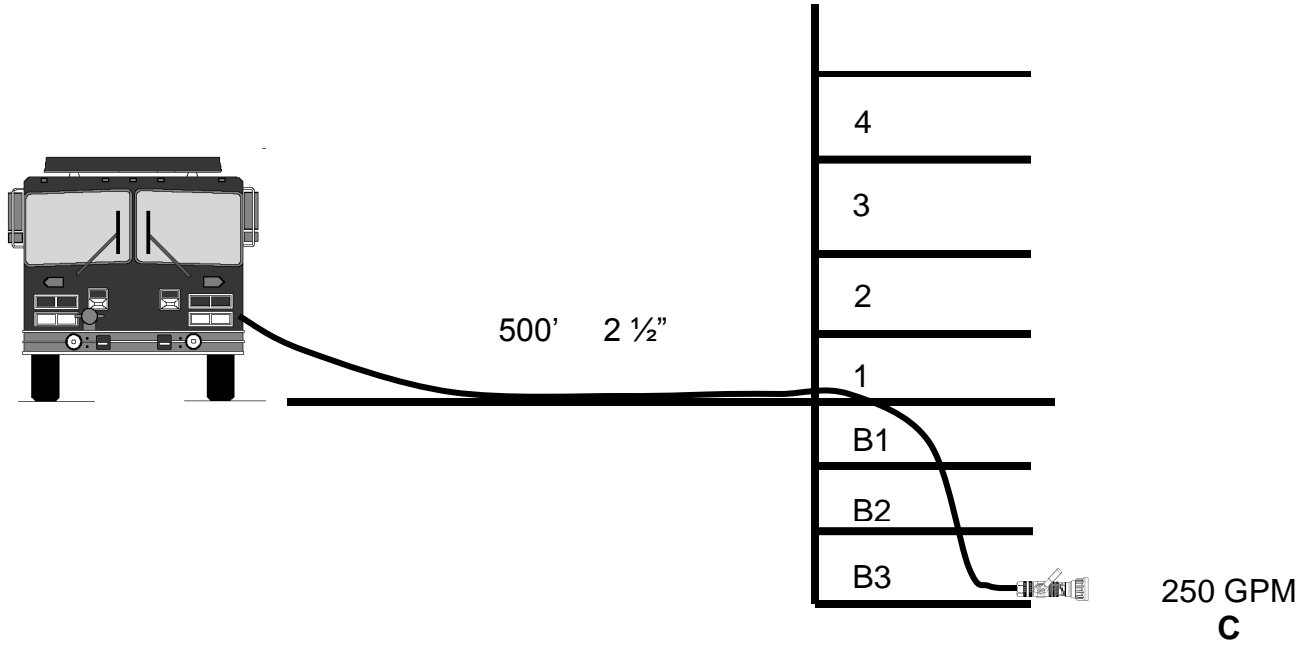

Write in answers

NP = _____

FL = _____

A = _____

±H = _____

EP = _____

TURN TO PAGE 214

$$\mathbf{EP = NP + FL + A (\pm) H}$$

15)ANSWERS

NP = 100 PSI

FL = 65 PSI

A = 0 PSI

H = -15 PSI

EP = 150 PSI

TURN TO PAGE 215

$$EP = NP + FL + A (\pm) H$$

16) Solve

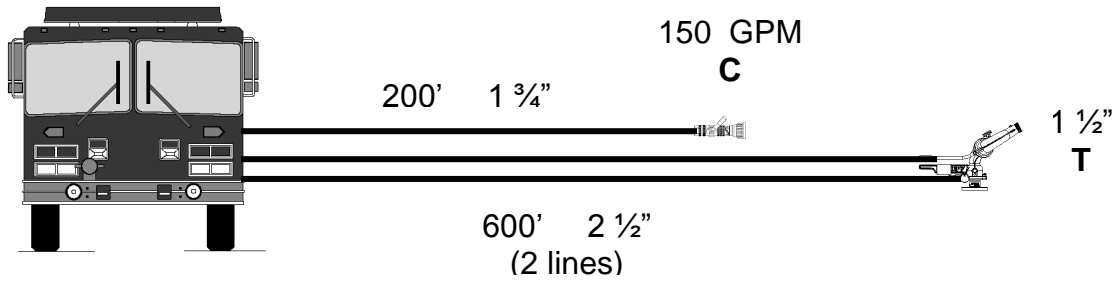

Write in answers

Portable Monitor

Handline

NP = _____

NP = _____

FL = _____

FL = _____

A = _____

A = _____

±H = _____

±H = _____

EP = _____

EP = _____

How would you obtain the correct pressure for the Handline?

TURN TO PAGE 216

$$EP = NP + FL + A (\pm) H$$

16)ANSWERS

Portable Monitor

NP = 80 PSI
FL = 108 PSI
A = 15 PSI
H = 0 PSI
EP = 203 PSI

Handline

NP = 100 PSI
FL = 70 PSI
A = 0 PSI
 $\pm H = 0$ PSI
EP = 170 PSI

Handline Answer:

By gating down.

TURN TO PAGE 217

$$EP = NP + FL + A (\pm) H$$

17) Solve

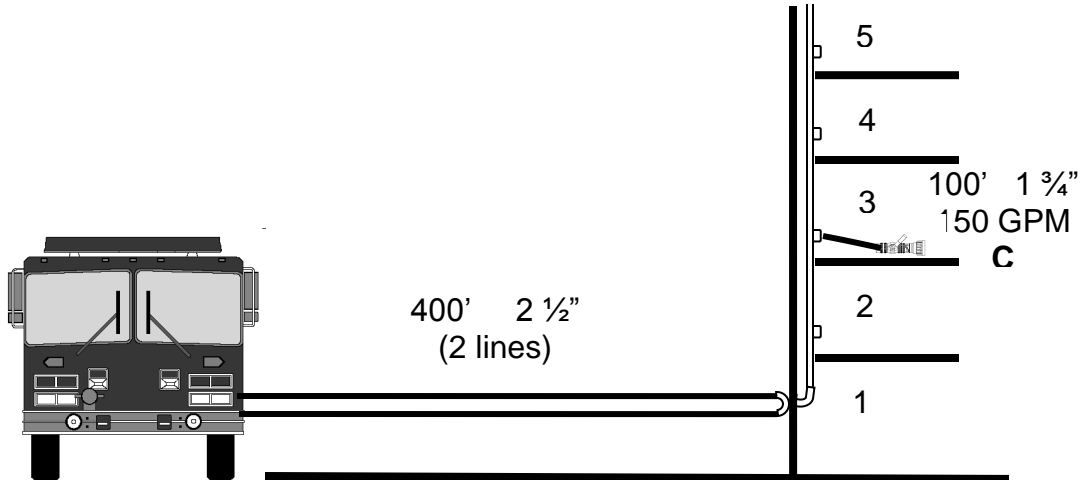

Write in answers

NP = _____

FL = _____

A = _____

$\pm H$ = _____

EP = _____

TURN TO PAGE 218

$$EP = NP + FL + A (\pm) H$$

17)ANSWERS

NP = 100 PSI

FL = 39.5 PSI

(1 $\frac{3}{4}$ inch hose 35 PSI FL)

(TWO 2 $\frac{1}{2}$ inch hose 4.5 PSI FL)

A = 25 PSI

H = +10 PSI

EP = 174.5 PSI

TURN TO PAGE 219

$$EP = NP + FL + A (\pm) H$$

18) Solve

A flammable liquid spill has ignited and is covering a surface area of approximately 1000 square feet.

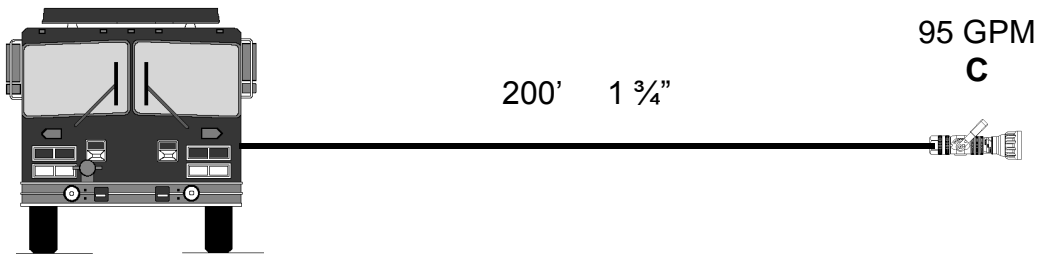

Write in answers

NP = _____

FAR = _____

FL = _____

TGPM = _____

A = _____

FCN = _____

±H = _____

FSA = _____

EP = _____

TURN TO PAGE 220

$$\mathbf{EP = NP + FL + A (\pm) H}$$

18)ANSWERS

NP = 100 PSI

FL = 28 PSI

A = 0 PSI

H = 0 PSI

EP = 128 PSI

FAR = 100

TGPM= 190

FCN = 86

FSA = 2838

TURN TO PAGE 221

$$EP = NP + FL + A (\pm) H$$

19) Solve

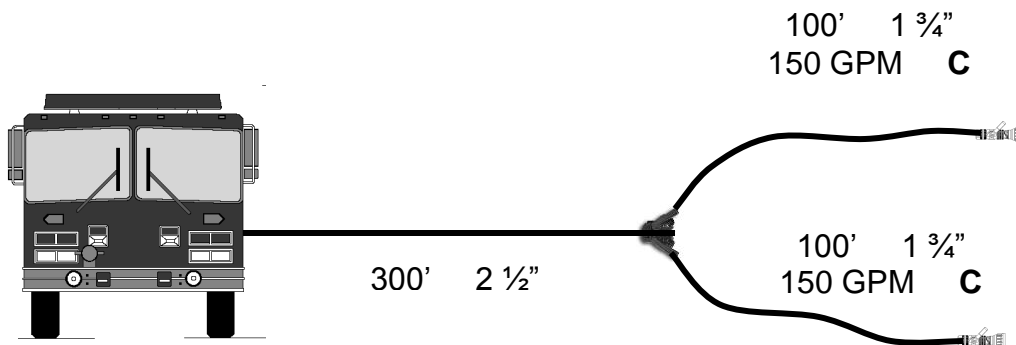

Write in answers

NP = _____

FL = _____

A = _____

$\pm H$ = _____

EP = _____

TURN TO PAGE 222

$$EP = NP + FL + A (\pm) H$$

19)ANSWERS

NP = 100 PSI

FL = 89 PSI

(1 $\frac{3}{4}$ inch hose 35 PSI FL)

(2- $\frac{1}{2}$ inch hose 54 PSI FL)

A = 10 PSI

H = 0 PSI

EP = 199 PSI

TURN TO PAGE 223

$$EP = NP + FL + A (\pm) H$$

20) Solve

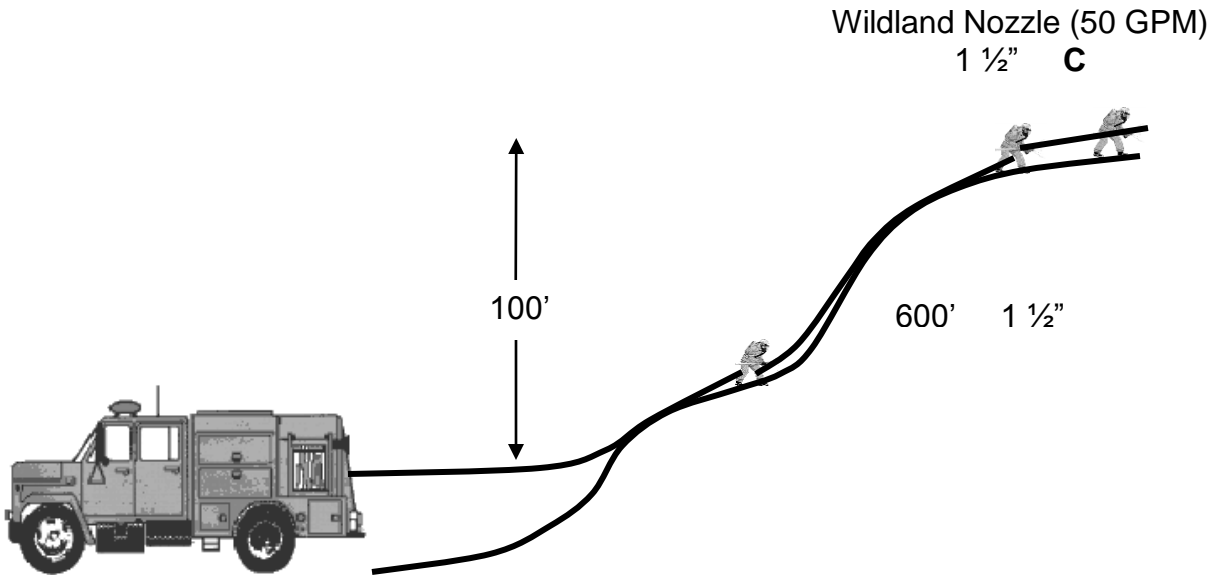

Write in answers

NP = _____

FL = _____

A = _____

$\pm H$ = _____

EP = _____

TURN TO PAGE 224

$$\mathbf{EP = NP + FL + A (\pm) H}$$

20)ANSWERS

NP = 100 PSI
FL = 36 PSI
A = 0 PSI
H = +43 PSI
EP = 179 PSI

THE END

CONGRATULATIONS!

You have completed the Federal Fire Department Hydraulics Manual. It is now up to you to take the information you have learned and start applying it to problems in the field. To become proficient, you must practice and continue to stay abreast with the information in this book.

Use the Pump Job Breakdowns to assist you in the proper steps.

Purpose

This manual has been developed with the intent of allowing prospective Federal Fire department Engineers to become proficient at basic fire service hydraulics on their own, at their own pace, using a standard, practical set of rules and a single formula. This manual also sets Department standards in the application of fire service hydraulics.

Reference

The International Fire Service Training Association (IFSTA) training materials.